

CC22020090

DI220200752

Proforma Invoice

<b>PREMIER ENGINEERS</b> NO 142, 1st Floor, Narayana Compound Kadugondanahalli Bengaluru Karnataka - 560045, India GSTIN/UIN: 29AQOPB7251L1ZD State Name : Karnataka, Code : 29	Voucher No. <b>190</b>	Dated <b>14-Feb-2022</b>
	Buyer's Ref./Order No. <b>Inquiry No. EN220200120</b>	Mode/Terms of Payment <b>100% After Supply</b>
Invoice to <b>JINDAL ALUMINIUM LIMITED</b> Bhiwadi division, SP-2/333, INDUSTRIAL AREA, BHIWADI, Rajasthan - 301019, India GSTIN/UIN : 08AAACJ4324M1ZH PAN/IT No : State Name : Rajasthan, Code : 08	Despatch through <b>VRL Logistics Ltd</b>	Other Reference(s) <b>Inquiry Date: 13.02.2022</b>
	Terms of Delivery <b>5 Days</b>	Destination <b>To Pay JINDAL Scope</b>

Sl No.	Description of Goods	HSN/SAC	Due on	Quantity	Rate	per	Amount
1	<b>Worm Gearbox</b> Model: A200, Ratio: 60/1	84834000	14-Feb-2022	1 No	10,799.00	No	10,799.00
	<b>IGST ROUND OFF</b>						1,943.82
							0.18
	Total			1 No			₹ 12,743.00

**CHECK LIST**

Discounted Rate as above

Incl

N.A.

30 days E.O.S.G E.&O.E

of material.

one, year

one week,

Company's Bank Details  
 Bank Name : Union Bank of India (India)  
 A/c No. : 133111100002069  
 Branch & IFS Code : KALYAN NAGAR & UBIN0813311  
 for PREMIER ENGINEERS

Authorised Signatory

This is a Computer Generated Document

10/1/22

Mrs. Vijaya Bhavani  
95 357 96780

discussed with  
Mr. Vijay Bhavani and  
agreed above  
etc

15/02/22

30 days E.O.S.G E.&O.E  
of material.  
BND Godown delivery

DRG.NO. IF IN DOUBT, ASKI

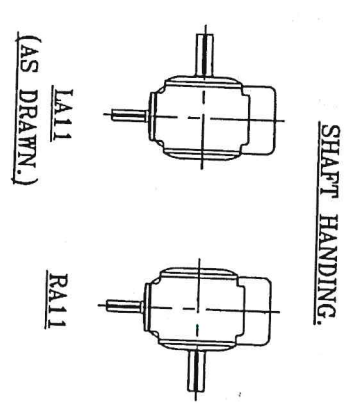
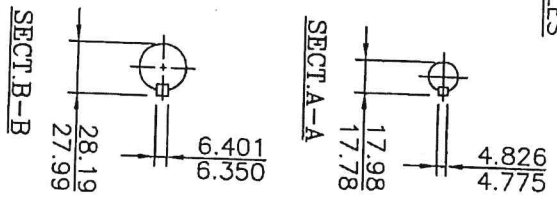
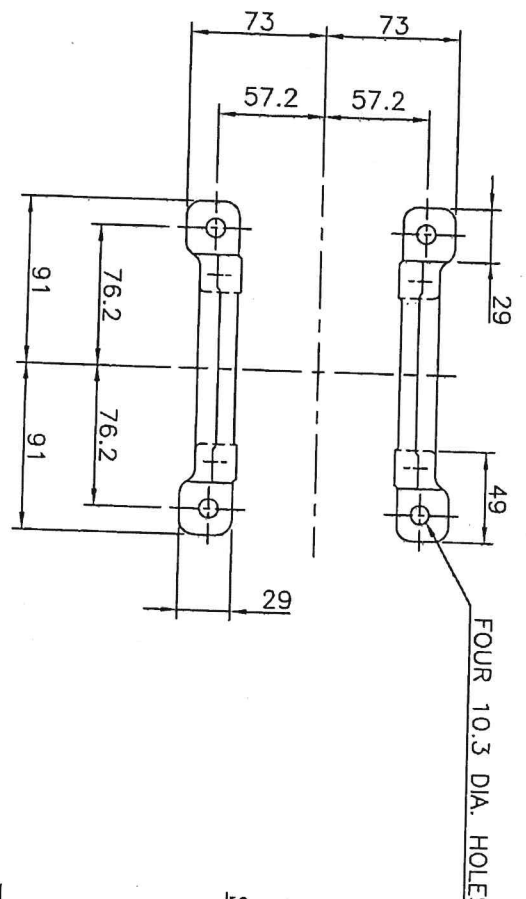
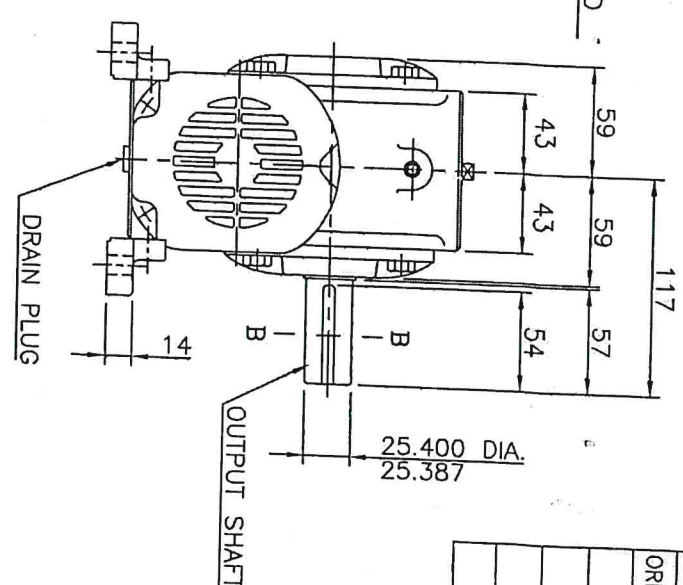
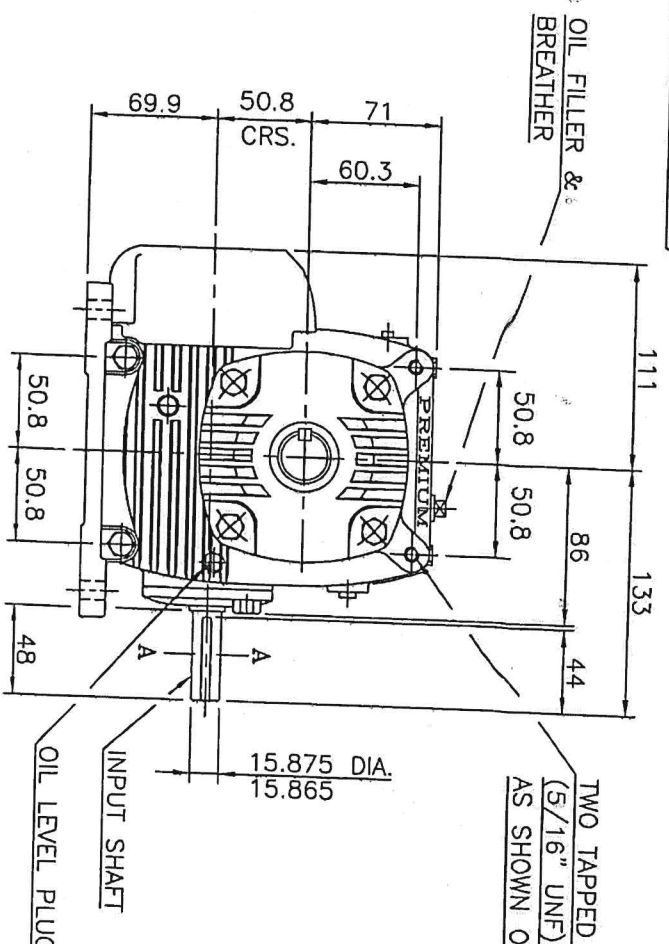

ALTERATIONS

ORDERS			
ORDER NO.	DATE	RATIO	QTY.

GEN ARRET FOR A 200 WORM REDUCTION UNIT WITH FOOT NO. 1 POSITION 1.

SCALE : 1:3

DRYAN DPC  
CHECKED RPG  
PASSED

PREMIUM Premium Transmission Limited  
Unit - 1  
Chinchwad Pune - 411019  
India

- KEYS ON INPUT & OUTPUT SHAFT, ACCORDING TO B.S.46 PART 1 : 1958
- THE GEAR UNIT IS NOT DESIGNED TO TAKE ANY EXTERNAL LOADS OTHER THAN THOSE SPECIFIED.
- DIMENSIONS FROM CAST SURFACES WITHIN ± 3MM
- ALL DIMENSIONS ARE IN MM UNLESS SPECIFIED OTHERWISE



# MAKHARIA MACHINERIES PVT.LTD.

H.O: 310/311, Nav - Neelam, Dr. R. G. Thadani Marg, Worli, Mumbai 400 018  
 Phone: 91 (22) 6602 3000 (100 Lines) Fax: 91 (22) 6602 3001  
 E-mail: [sales@makharia.in](mailto:sales@makharia.in) Website: [www.makharia.in](http://www.makharia.in)  
 CIN NO. U31300MH1995PTC087908

EMAIL : [rajgopal@jindalaluminium.com](mailto:rajgopal@jindalaluminium.com)  
 REF. : MMPL/AM/ML/AS-6224/21-22

To,  
 M/s. JINDAL ALUMINIUM LIMITED.  
 Bhiwadi Division,  
 SP-2/333, INDUSTRIAL AREA,  
 BHIWADI - 301019,  
 ALWAR DIST,( RAJASTHAN )  
 GST No. 08AAACJ4324M1ZH

Kind Attn. : Mr. Rajgopal Sarda  
 Ref. : Your Email Enquiry Dated 18/02/2022

Dear Sir,

This is with respect to your email enquiry, we are pleased to offer you as under :

1NO. RADICON MAKE WORM REDUCTION GEAR BOX, SIZE: A-200, RATIO – 60 : 1,  
 HORIZONTAL FOOT T MOUNTED

LIST PRICE: RS. 31,610/- (-) 66% DISOCUNT + 1% P&F + TAXES 18% GST – EACH

**TERMS & CONDITIONS :**

- DELIVERY : READY STOCK. SUBJECT TO PRIOR SALE.
- PRICES : THE ABOVE PRICES ARE F.O.R. UP TO TRANSPORTER GODOWN.
- PAYMENT : 100% ADVANCE AGAINST PROFORMA INVOICE.
- VALIDITY : 7 DAYS.
- FREIGHT & INSURANCE WILL BE EXTRA TO YOUR ACCOUNT.

Regards,

MANJU LALWANI - 022-6602 3005 / 892 893 1487  
 Email – [manju@makharia.in](mailto:manju@makharia.in)

DISCOUNT	Rate as below
PH. NO.	9611195368
DATE	18/02/2022
ED	NA
DELIVERY WAY	IGST: 18% Extra
DELIVERY TERM	30 days credit
FOR	FOR - BWP. Etc
VALIDITY	one year
	one week

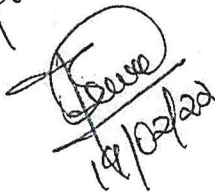
*discussed with Mr Manju  
 and not agreed to  
 reduce price  
 further*  
  
 19/02/22

**AUTHORISED CHANNEL PARTNERS**

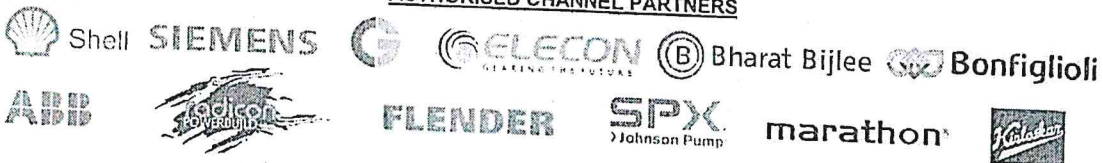

Dealing In  
 Motors, Pumps, Gearboxes, Geared Motors, Drives, Lubricants & Grease