

HYDMARK APPLICON

A 5/4 & 6/4, PHASE II, INDUSTRIAL AREA, MAYAPURI
NEW DELHI - 110064
PHONE: +91-11-45114611-30 lines, FAX: +91-11-28116246
E-mail: sales@hydmark.com

QUOTATION

OUR REF. HAQ/JAL/22-23/1396

DATE 31.01.2023

M/s. Jindal Aluminum Ltd.,
Jindal Nagar, Tumkur road,
Bangalore- 560 073, India
Email: rajgopal@jindalaluminium.com
Tel.: 080- 27735011, 27735051

YOUR REF.: - Your email dated- 24.01.2023

Kind Attn.: - Mr. Rajgopal. C. Sarda.
(Asst. Manager - Purchase)

MOB: +91 9611-195-368

Dear Sir,
We feel pleasure in forwarding our quotation for the following:

S. NO.	DESCRIPTION	QTY.	UNIT PRICE
1.	<p>ASSLY OF CONTAINER CYLINDER FOR PRESS BP-1</p> <ul style="list-style-type: none"> ❖ Type : Double acting ❖ Bore : Ø250 mm ✓ ❖ Rod : Ø160 mm ✓ ❖ Stroke : 1016 mm ✓ ❖ Mounting : As per your drawing ❖ Working pressure : 280 bar ❖ Test pressure : 300 bar ❖ Seals : ISO Standard ❖ Max. working temp. : 65°C ❖ Cushioning : None ❖ As per your drawing no. : BP1-1650-04-A3 ❖ Material of construction <ul style="list-style-type: none"> ▪ Made / Machined out of single bar stock ▪ Piston rod - CK45/C45 ▪ Flange & glands - C20 ▪ Fasteners - high tensile ▪ Chrome plating thickness on rod - 20-30 microns ▪ Rod surface roughness Ra 0.2 / 0.4 microns 	01 No.	<p>@ ₹ 5,19,750.00 Each</p> <p>(@ Rupees five lacs nineteen thousand seven hundred fifty only)</p> <p><i>Discussed with Mr. Oberoi He is agreed 10% Discount on above Price are final</i></p> <p><i>Rupesh Sarda 06/2/23</i></p>
2.	<p>ASSLY OF SIDE CYLINDER FOR PRESS BP-1</p> <ul style="list-style-type: none"> ❖ Type : Double acting ❖ Bore : Ø200 mm ❖ Stroke : 1675 mm ❖ Mounting : As per your drawing ❖ Working pressure : 300 bar ❖ Test pressure : 350 bar ❖ Seals : ISO Standard ❖ Max. working temp. : 65°C ❖ Cushioning : None ❖ As per your drawing no. : BP1-1650-03-A3 ❖ Material of construction <ul style="list-style-type: none"> ▪ Made / Machined out of single bar stock ▪ Piston rod - CK45/C45 ▪ Flange & glands - C20 ▪ Fasteners - high tensile ▪ Chrome plating thickness on rod - 20-30 microns ▪ Rod surface roughness Ra 0.2 / 0.4 microns 	01 No.	<p>@ ₹ 4,45,500.00 Each</p> <p>CHECK LIST</p> <p>DISCOUNT : 10% Discount on above (@ Rupees four lacs forty five thousand five hundred only)</p> <p>PRICE BASIS : FOR BHIWADI FOR JAL</p> <p>P & F : INCL. / EXTRA NIL</p> <p>GST/IGST : 18% GST Extra</p> <p>DELIVERY : 30 days 45 day to 60 days</p> <p>PAYMENT : 30 days</p> <p>GCM/CTC : One year warranty</p> <p>VALIDITY : <i>Rupesh</i></p>

Our terms & conditions of business are as per the details listed below.



Dated : 06.01.2023

M/s Jindal Aluminium Limited
SP-2/333, Industrial Area
Bhiwadi Dist., Alwar
Rajasthan - 301 019

Dear Sir,

Final Price

S.No.	Item Description	Drawing No.	UOM	Quantity	Price	Total
1	Hydraulic Double Acting Cylinder 250x160x1016 ✓	BP1-1650-04-A3 ✓	Nos.	1	3,75,000.00	3,75,000.00
2	Assly. Of Side Cylinder for Press 180x115x685 ✓	BP1-1650-03-A3	Nos.	1	1,38,600.00	<u>1,38,600.00</u>
3	Assly. Of Butt Shear Cylinder 200x300x1675	BP1-1650-19-A2	Nos.	1	3,78,000.00	3,78,000.00
	Total			3	8,91,600.00	8,91,600.00
4	GST 18%					1,60,488.00
	Total					10,52,088.00

Payment Terms : 50% Advance and 50% against Performa.
Handling Charges 5%.
Freight as actual.

Thanking You,

For Micro Hydrotechnic Pvt. Ltd.

(Charanjeet Kaur)
Sales Department

*Discussed with Mr. Sumit
He is agreed 15% Discount
on above Price*

*Rupesh Jami
06/12/23*

CHECK LIST

DISCOUNT : *above Price are final*

PRICE BASIS : *Final*

TAXES : *Extra*

STAGES : *18% GST Extra*

DELIVERY : *45 days*

PAYMENT : *15 days*

WARRANTY : *Six month warranty.*

CHECKED BY : *Rupesh*

rubber part not work

Micro Hydrotechnic Pvt. Ltd.

Regd. Office : Micro House B-93 , Maya Puri Industrial Area
Phase - 1 Opp T&T Motors (Mercedes) | New Delhi-110064
Works : Plot No.223 & 224, Sector-9, Phase-III, Industrial Growth Centre, IMT Bawal,
Rewari, Haryana-123501
CIN : U29199DL2003PTC122301
Mobile : 9350230826, 9717474831
Landline : 011-40644399
Email : sales@microhydrotechnic.co.in, vartika.mahajan@microhydrotechnic.co.in
GSTIN No. Delhi : 07AADCM9466C1ZD
GSTIN No. Bawal : 06AADCM9466C1ZF
Website : www.microhydraulicpress.com

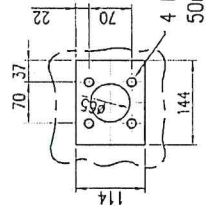
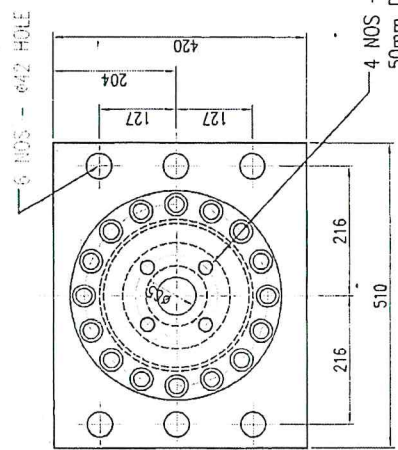
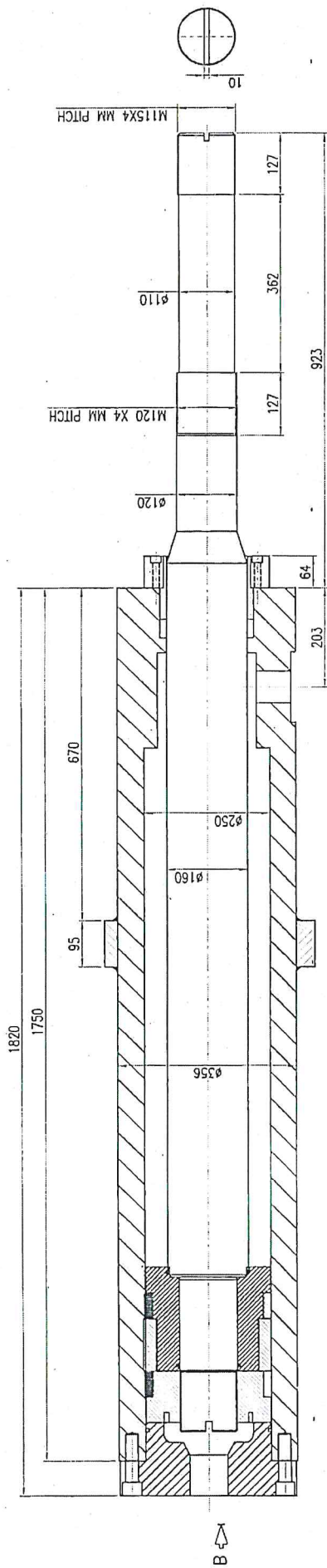

NOTE :-

1. PISTON ROD - ϕ 160
2. CYL. BORE - ϕ 250
3. STROKE - 1016
4. WORKING PRESSURE - 280 BAR
5. WORKING TEMP. - 65° C, MEDIA - HLP-68
6. COMPACT PISTON SEAL WITH 3 PIECES DESIGN TO BE USED.
7. CYLINDER SHOULD COME WITH GLAND PACKING 1+3+1 TYPE

JINDAL ALUMINIUM LTD.

SP-2/333, INDUSTRIAL AREA,
BHIWADI, RAJASTHAN-301019

ALL DIMENSIONS ARE IN mm., UNLESS OTHERWISE SPECIFIED

SCALE
1:1

ASSLY OF CONTAINER CYLINDER FOR
PRESS BP1 (GA DRAWING)

DRAWING NO.
BP1-1650-04-A3

NO	DATE
VIKAS	01-12-21
DRH.	
CHKD.	07/07/22
APPO.	12/07/22