



Jindal Aluminium

Bhiwadi Purchase . <purchase.bhiwadi@jindalaluminium.com>

**QUOTAION FOR 16" BONMAC DOG CHUCK WITH BACKPLATE**

atul shah <shahatul1008@gmail.com>  
To: purchase.bhiwadi@jindalaluminium.com

Fri, Jan 20, 2023 at 12:58 PM

DEAR SIR,

WITH RESPECT TO YOUR INQUIRY WE ARE PLEASED TO QUOTE YOU AS FOLLOWS,

1) "BONMAC (ZITHER)" 16" (400mm) X 4 Jaw Heavy Duty Independent Dog Chuck with Hard Reversible Jaw, Bolt & key but Without Back Plate.

Amount- ~~Rs 23900/-~~

Disc-23%

DELIVERY-READY

*Handwritten:* 184037 GST Nett  
17925 + amt

2) "BONET (ZITHER)" 16" (400mm) X 4 Jaw EXTRA Heavy Duty Independent Dog Chuck with Hard Reversible Jaw, Bolt & key but Without Back Plate.

Amount- Rs32300/-

Disc-23%

DELIVERY-3-4 WEEKS

3) SPARE BACKPLATE FOR ABOVE CHUCK SUITABLE FOR NH26 LATHE MACHINE DI-8 CAMLOCK STUD

Amount- Rs15000/-

Disc-NETT

DELIVERY-3-4 WEEKS

*Handwritten:* ⇒ 17925 + 15000 = 32925/- Per Nos

*Handwritten:* final price  
Rupesh for  
20/1/23

HSN NO-8466

TAX - 18% GST

Packing & Forwarding - Extra

PAYMENT- Against Proforma

Awaiting your Valued Order per return and in the meanwhile Thanking You

Thanks &

Atul Shah

**PARAS MACHINE TOOLS**

158/160, NARAYAN DHURU STREET,

1ST FLOOR,

MUMBAI - 400003

NEW TEL. NO: 022-23461797

Mob: 09820151797 / 09833151797

EMAIL : shahatul1008@gmail.com

**GST NO:- 27AAVFP7347J1ZD**

CHECK LIST	
DISCOUNT	: above Price are final
PRICE BASIS	: FOR BHIWADI Ex-work
P & F	: INCL...../ EXTRA... Extra
GST/IGST	: 18% GST Extra
DELIVERY	: 10 days to 15 days
PAYMENT	: against PI
GC/WC/TC	: —
VALIDITY	: —
CHECKED BY :	Rupesh

# ZITHER® Back Plates / Mounting Flanges

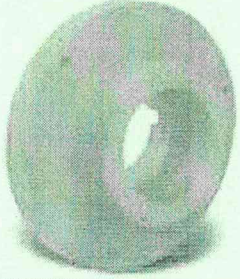
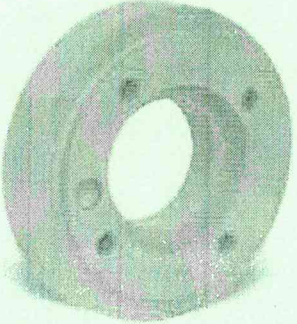
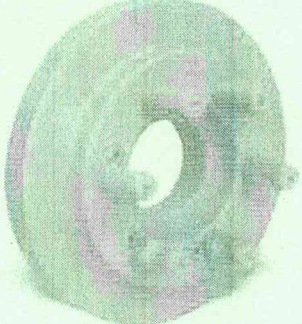
	<b>Model</b>	Suitable for Popular Models of Lathes manufactured in India
	<b>L1</b>	LB-17/20/25, H-22/26 (HMT) PSG A-124-124
	<b>A2-4</b>	Turnmaster-35, EP-380 (Kirloskar) PSG A-141E
	<b>A2-5</b>	Rocio-180/200, Smart Turn
	<b>A2-6</b>	Turnmaster-40/45 (Kirloskar) NH-22/26 NL-22/26 (HMT) LTM-20 LML-20, LT-20 L-22 TP (HMT) 9B/VIKRAM A24UP(HMT)
	<b>A2-8</b>	NH-32 (HMT) PSG 600/660 BECO MO630P Turnmaster 50 (Kirloskar)
	<b>A2-11</b>	BECO HD 40-50
	<b>D1-4</b>	Turnmaster-35/Nagmati-175, EP-1330/1550/355 (Kirloskar)
	<b>D1-5</b>	PINACHO SP180, SP200
	<b>D1-6</b>	Turnmaster-40/45 (Kirloskar) EP-1675 400/425 (Kirloskar) VIKRAM (HMT) PSG 400/500
	<b>D1-8</b>	Turnmaster-50 (Kirloskar) EP-1810/450/500 (Kirloskar) B-32 / SB-CNC (HMT) PSG 500,600,660
		EP-2210/2215/2615 (Kirloskar)

## "BONET" Extra Heavy Duty 4-Jaw Independent Chucks

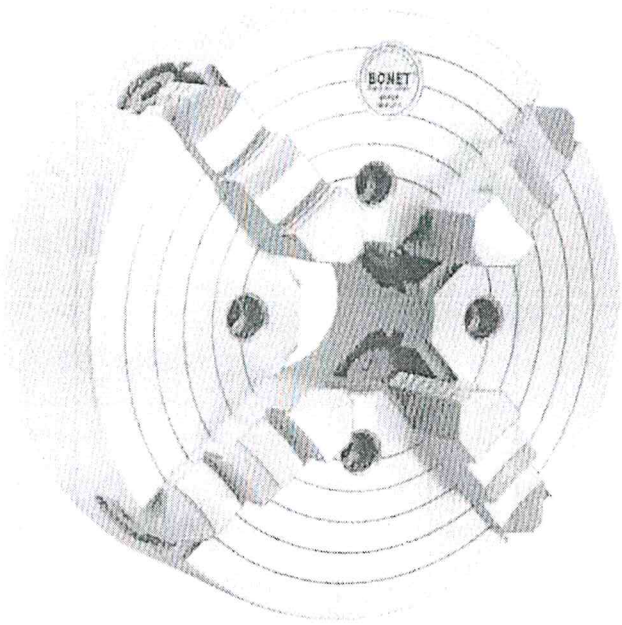

**B**ONET Extra Heavy Duty chucks referred as EHI are manufactured to cope with toughest working conditions. They are capable of carrying heavy loads. The height of bodies though more, but it helps not break under the loads. The jaw-ways in are of robust proportion which can withstand heavy loads diameter of screws is large enough to tolerate heavy cutting pressure and moreover large diameter of screws provide more contact with thread of jaws. ACME threads of screws are very strong. Some have 29 degree taper. These do not break easily due to stress provided by large base of taper thread. Alloy steel having Nickel Chromium and Molybdenum is used in the manufacture of Self Thrust Bearings and Operating Key which are heat-treated to give wear resistance and toughness. Chucks from 160mm onward have double type thrust bearings of robust proportions which provide great strength. Operating Key, Mounting Bolts, Allen Key, Test Inspection Report is provided with each chuck.

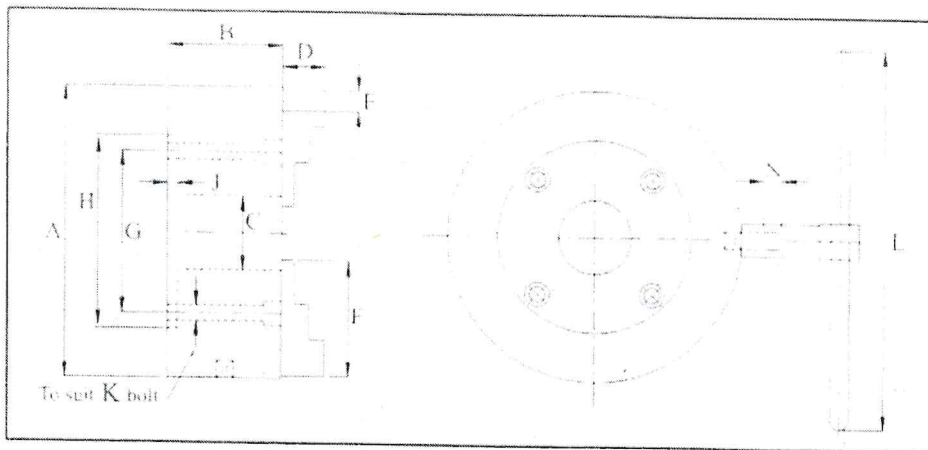

*Product Code	Size	A	B	C	D	E	F	G	H	J	K	L	N	WE
5092-6	6"	152	78	45	25	23.9	55	105	127	6	M10	165	8	
5092-8	8"	203	93	50	32	30.1	80	110	85	6	M10	215	10	
5092-10	10"	254	94	60	39	34.9	90	126	100	8	M12	265	11	
5092-12	12"	305	101	75	45	38.1	105	140	160	10	M12	340	12	
5092-14	14"	355	101	85	52	38.1	115	155	175	10	M12	340	12	
5092-16	16"	406	107	100	54	44.5	125	175	200	10	M16	420	13	
5092-18	18"	457	107	100	54	44.5	150	175	200	10	M16	420	13	

\* The Product codes in the table are for BONET 4-Jaw Independent Chuck with Cast Iron Body. Please refer the Last Page to know how to use the Product Code

## "BONMAC" Heavy Duty 4-Jaw Independent Chucks

**B**ONMAC Heavy Duty chucks referred as HD, are suitable for normal working conditions. However these chucks will stand well ahead in Quality, Load carrying capacity and Life if compared with other competitive brands available in the market. Where other brands of chucks fail to give service, Bonmac chucks will give trouble free service for long period. The jaw-ways in body are of robust proportion which can withstand heavy loads. The diameter of screws is large enough to tolerate heavy cutting pressure and moreover large diameter of screws provide more contact area with threads of jaws. ACME threads of screws are very strong as the same have 29 degree taper. These do not break easily due to strength provided by large base of taper thread. Chucks from 160mm onward have double type thrust bearings of robust proportions which provide great strength. Operating Key, Mounting Bolts & Inspection Report is provided with each chuck.

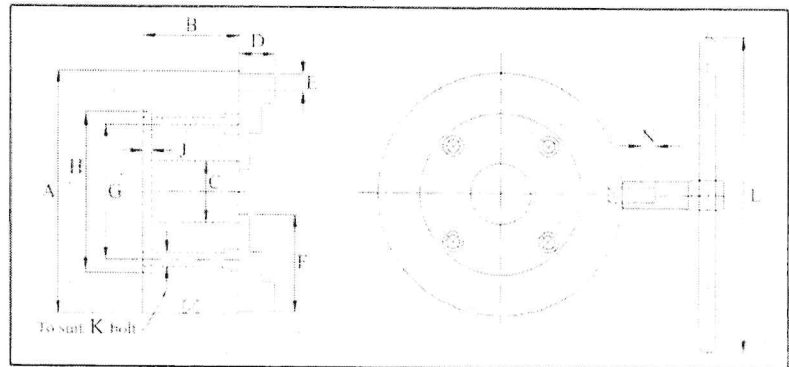
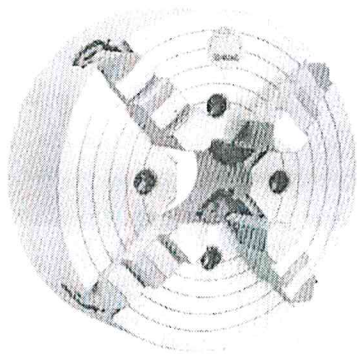

Product Code	Size In mm.	A	B	C	D	E	F	G	H	J	K	L	N	W/ Bolt IN mm
6093-80	80	82	45	20	20	12	32	60	70	4	M6	90	5	2
6093-100	100	102	55	25.4	22	19	48	70	85	5	M8	120	7	3
6093-125	125	125	55	32	22	19	48	80	100	5	M8	140	7	4.5
6093-160	160	160	75	45	24	23.9	55	138	120	6	M10	165	8	9
6093-200	200	200	87	50	32	29.9	75	100	80	6	M10	215	10	15.5
6093-250	250	250	87	60	33	29.9	85	110	130	8	M10	265	10	21.5
6093-305	305	305	95	75	45	34.9	100	140	160	10	M12	340	12	36.5
6093-350	350	350	95	85	51	34.9	110	140	160	10	M12	340	12	43
6093-400	400	400	105	100	60	40.7	125	175	200	12	M16	420	13	64
6093-450	450	450	105	100	60	40.7	150	175	200	12	M16	470	13	76.5
6093-500	500	510	115	110	66	47	170	235	260	12	M20	520	14	113.5
6093-600	600	610	115	140	66	47	170	235	260	12	M20	620	14	133.5

## QUOTATION

CONSIGNOR	CONSIGNEE	
<b>DUNDHI MACHINE TOOLS</b> A6/104,SATYAM APPATMENT,NEAR RAIPUR MILL RAKHIYAL ROAD, AHMEDABAD-380021 GUJARAT,INDIA MOB: 9558824311 www.dundhimachinetools.com dundhimachinetools@gmail.com GST No.24AKEPR0497G1Z2 PAN: AKEPR0497G	<b>NO:</b> 153 <b>Date:</b> 9/1/2023 <b>Bill To:</b> JINDAL ALUMINIUM LTD. (BHIWADI DIVISION) <b>Address:</b> SP-2/333, INDUSTRIAL AREA, ALWAR DIST BHIWADI - 301019 ,( RAJASTHAN )  <b>Phone:</b> 9611195368 <b>GSTIN:</b> 08AAACJ4324M1ZH <b>E-mail:</b> purchase.bhiwadi@jindalaluminium.com	

Description	Units	Cost Per Unit	Amount
SPARE FOR HMT NH-26 LATHE MACHINE 16"X4 JAW INDEPENDENT CHUCK WITH BACKPLATE TO SUIT HSN 8487 (Make → Bonmac)	1	33150.00	33,150.00

### CHECK LIST

DISCOUNT : above Price are final

PRICE BASIS : FOR BHIWADI Ex-Work

P & F : INCL...../EXTRA Extra

GST/IGST : 18% Gvt Extra

DELIVERY : 10 to 15 days

PAYMENT : Against PI

GC/WC/TC : —

VALIDITY : —

CHECKED BY : Rupprekha

Final Price  
Rupprekha  
20/1/23

**Terms And Conditions**

DELIVERY : 1 WEEK FROM THE DATE OF ORDER  
 P & F : @3% EXTRA  
 TAXES : CSGT@9% AND SGST@9% OR IGST@18%  
 PAYMENT : AGAINST PI  
 FREIGHT : EXTRA @ ACTUAL  
 VALIDITY : 30 DAYS  
 SUBJECT TO AHMEDABAD-380021 JURISDICTIONS  
 COMPUTER GENERATED COPY HENCE DOESN'T REQUIRED SIGNATURE

**33,150.00**