



# INDRO INDUSTRIES



AN ISO 9001: 2008 CERTIFIED COMPANY

ENGINEERS, MANUFACTURER & FABRICATORS

13/6, NATABAR PAUL ROAD (KADAMTALA) HOWRAH - 711 101. WEST BENGAL  
TEL.NO.033-2643-8105, E.MAIL:indroindustries@yahoo.co.in Website: www.indroindustries.com

## QUOTATION

QUOTATION NO-II/Q/472/2022-23  
REF ENQ. NO. : EN221001882

DATE 02.11.2022  
DATE 02.11.2022

TO,  
M/S. JINDAL ALUMINIUM LTD.  
BHIWADI

Dear Sir

Thanking you for your above enquiry and we are pleased to submit our lowest best offer. Our terms & conditions are given below.

*Final Price  
Rupees  
28/l2*

SL.NO.	Item Code.	Materials Description	Quantity	Prices	Per
1.	06981134	IMPELLER OF LOG HEATING FURNACE FOR BP3 PRESS (DRAWING NO.- LHF-BP3-01-A4, PART NO. 2),AS PERDRAWING NO.- LHF-BP3-01-A4, PART NO. 2 (BOTH FETING TOGETHER SHAFT AND IMPELLER ),	01 NO.	49,000/-	EACH
2.	06981135	BLOWER SHAFT OF LOG HEATING FURNACE FOR BP3 PRESS (DRAWING NO.- LHF-BP3-01-A4, PART NO. 1),AS PER DRAWING NO.- LHF-BP3-01-A4, PART NO. 1 (BOTH FETING TOGETHER SHAFT AND IMPELLER ),	01 NO.	8,900/-	EACH
3.	06981133	BEARING HOUSING OF FINISH SAW FOR BP3 PRESS (DRAWING NO.- APS-BP3-05-A4),AS PER DRAWING NO.-APS-BP3-05-A4	01 NO.	17,500/-	EACH

HSN CODE: 98010030

We trust our offer will be acceptable to you and will be favored with your valued order.

### TERMS & CONDITIONS.

- SALES TAX : G.S.T. 18% WILL BE CHARGE EXTRA
- TRANSPORTATION : DOOR DELIVERY BASIS
- PAYMENT : WITH IN 30 DAYS.
- DELIVERY : WITHIN 8-10 WEEKS
- INSPECTION : AT YOUR WORKS
- VALIDITY : 30 DAYS

**CHECK LIST**

DISCOUNT : *5% on above price*

PRICE BASIS : FOR BHIWADI. *FOR TAL*

P & F : INCL. — / EXTRA —

GST/IGST : *18% Ex tax*

DELIVERY : *10 Weeks*

PAYMENT : *30-days*

GCM/CTC : —

VALIDITY : —

CHECKED BY : *Rupesh*

FOR INDRO INDUSTRIES  
[ARUP KUMAR BANERJEE]

OUR G.S.T. NO. 19AAFFI1702C1ZX

# Golden Engineering & Enterprises

Address: Kamardanga, Pallabpukur, Santragachi, Howrah - 711104  
State: WEST BENGAL(19)

GSTIN: 19AESPM2302K2Z7

PAN: AESPM2302K

Mobile: 9830250045

Phone: 033 2667 2449

Website: www.goldenengineering.co.in

Email : golden.mondal@gmail.com

## QUOTATION

### QUOTATION TO (DETAILS OF RECEIVER)

Name: JINDAL ALUMINIUM LIMITED  
(BHIWADI DIVISION)  
Address: SP-2/333, RICCO INDUSTRIAL  
AREA, BHIWADI, ALWAR, BHIWADI,  
RAJASTHAN, 301019  
Mobile:  
GST No: 08AAACJ4324M1ZH  
State : RAJASTHAN  
State Code: 8

Quotation No. : QUO/Q/548/2022-23

Date: 22-10-2022

Ref./PO No. : EN221001882

Ref./PO Date : 21-10-2022

S.No.	Item Name Description	HSN/SAC	UoM	Qty	Rate	Dis(%)
1	IMPELLER IMPELLER OF LOG HEATING FURNACE FOR BP3 PRESS (DRAWING NO.- LHF-BP3-01-A4, PART NO. 2),AS PER DRAWING NO.- LHF-BP3-01-A4, PART NO. 2 (BOTH FETING TOGETHER SHAFT AND IMPELLER ),	8414	pieces	1	NaN	0.00
2	06981133 BEARING HOUSING OF FINISH SAW FOR BP3 PRESS (DRAWING NO.- APS-BP3-05-A4),AS PER DRAWING NO.- APS-BP3-05-A4,	8483	Sets	1	8580 ✓	0.00
3	06981135 BLOWER SHAFT OF LOG HEATING FURNACE FOR BP3 PRESS (DRAWING NO.- LHF-BP3-01-A4, PART NO. 1),AS PER DRAWING NO.- LHF-BP3-01-A4, PART NO. 1 (BOTH FETING TOGETHER SHAFT AND IMPELLER ),	8483	pieces	1	8215 ✓	0.00

### CHECK LIST

Total

3

16795

E &amp; O E

Terms &amp; Conditions:

RATES - Ex. Works, Howrah.  
G.S.T - Extra, 18% as applicable  
PAYMENT - 30 days Credit Maximum.  
DELIVERY - Within 30 - 45 Days.  
PACKING - Inclusive.  
INSPECTION - At Your Side.  
VALIDITY - 15 days from the date hereof.

DISCOUNT : 3% on above price

PRICE BASIS : FOR BHIWADI FOR JAL

P &amp; F : INCL. - / EXTRA. -

GST/GST : 18% Extra

DELIVERY : 45 - days

PAYMENT : 30 - days

GC/WC/TC : -

VALIDITY : -

CHECKED BY : Rupak

For Golden Engineering &amp; Enterprises

↔ A

4 NOS-M8 TAPPED HOLE ON 80 PCD

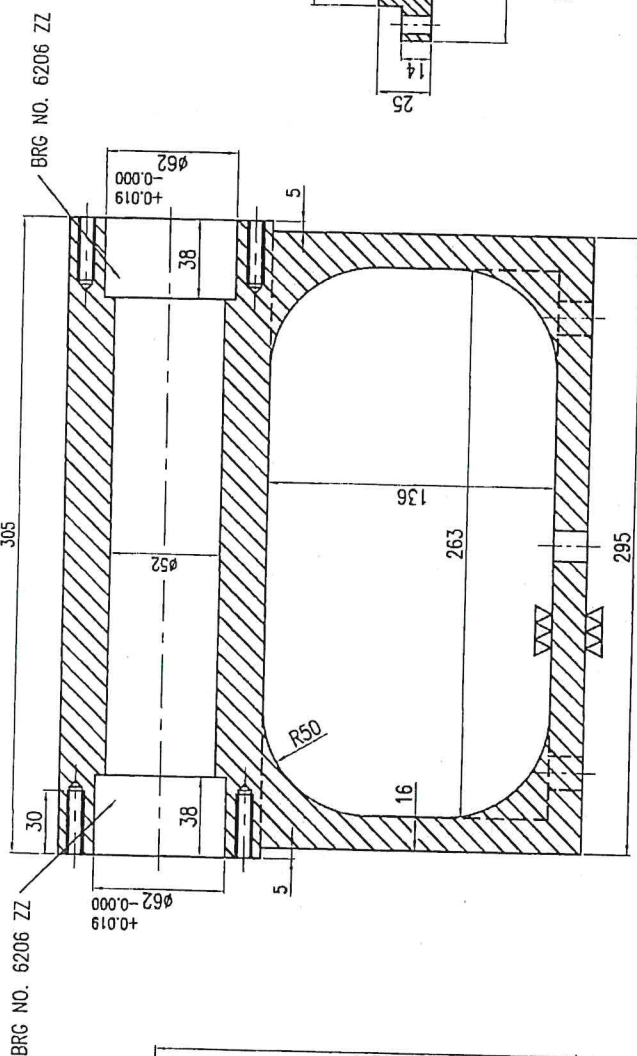
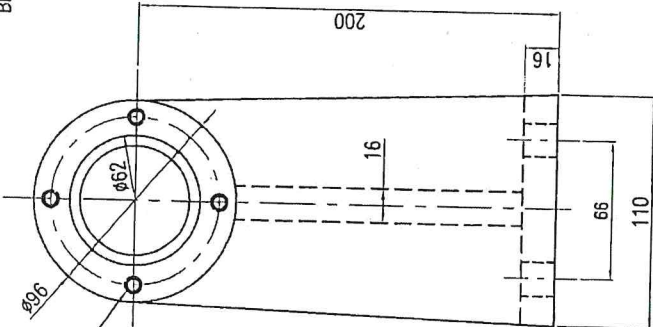

4 NOS.-09 THRU HOLE ON 80 PCD.

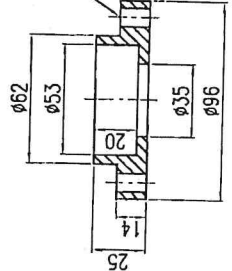

BEARING PLATE  
QTY.-2 NOS  
MATERIAL :- M.S

↔ A

5 NOS.-16 THRU HOLE

BEARING HOUSING  
MATERIAL :- C.I

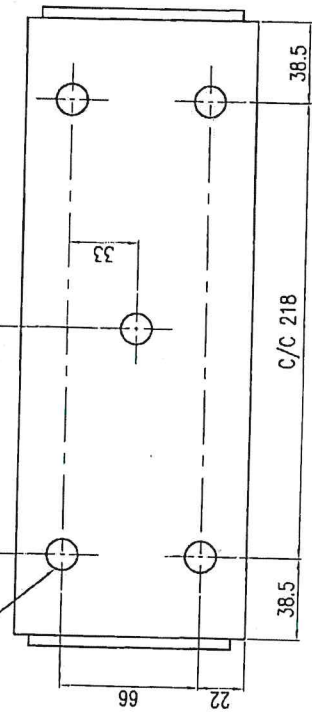

BOTTOM VIEW

OK  
07/10/22

JINDAL ALUMINIUM LTD.  
SP-2/333, INDUSTRIAL AREA,  
BHIWADI, RAJASTHAN-301019

ALL DIMENSIONS ARE IN mm., UNLESS OTHERWISE SPECIFIED

SCALE  
1:1



BEARING HOUSING OF FINISH  
SAW FOR BP3 PRESS

DRN.	NAME	DATE
VIKAS	VIKAS	07.10.22
CKD.	CKD.	07.10.22
APPD.	APPD.	07.10.22

DRAWING NO.  
APS-BP3-05-A4

