

GARGI MHE SOLUTIONS

SHOP NO-90, NEAR ROSE LAND PUBLIC SCHOOL, NITIN VIHAR HERO HONDA CHOWK,
GURGAON-122101

MOBILE: 9871909126, 9871029126, 9871129126

EMAIL: salesrajesh21@gmail.com,

salesgargi21@gmail.com

GST NO: 06CIAPD5841G1ZM

MAKE YOUR BUSINESS GOODS/ITEMS MOVEMENTS EASIER

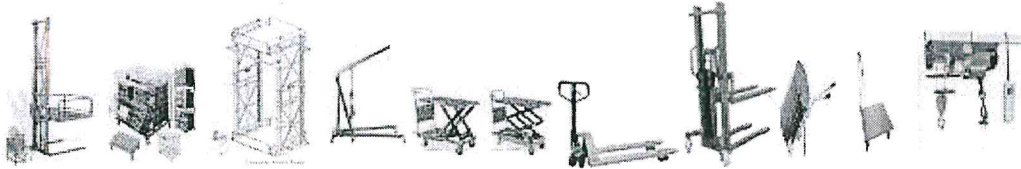

SUBJECT : QUOTATION FOR LIFTABLE

Dear Sir,

This has reference to your telephonic conversation with **the undersigned** regarding your interest for Hydraulic lifttable.

In this connection we are giving below the details of equipment along with terms & conditions for sale. In all over India.

We are manufacturer of all type of material handling equipment, hydraulic handling equipment, drum handling equipment, aluminum ladder, platform truck, hand truck with as per customer's requirement.

THAT ALL SPARE PARTS AVAILABLE IN EX-STOCK

TRAINED SERVICE TECHNICIANS AVAILABLE ALL OVER INDIA

weight: 135 kgs

LIFTABLE

Model	GARGI 800
Capacity	800 Kg.
Length	1200 mm
Width	600 mm
Min.Ht.	330 mm
Max.Ht.	1500 mm
Price	Rs.54,500/-
ROLLER ATTACHMENT	18000/- EXTRA
DELIVERY	Ex-stock at present subject to prior sale (otherwise 2 weeks)

→
→
→
→

*Final Rate
Rs. 52,500/-*

CHECK LIST

DISCOUNT *Rate as above*

PRICE BASIS *Ex-works - Gurgaon*

P & F *INCL. / EXTRA*

GST/IGST *IGST: 18% Y. Bar*

DELIVERY : *10 days*

PAYMENT : *7 days credit*

VALIDITY : *one year*

CHECKED BY : *Rajgopal*

*Discussed with
Mr. Deepa and agreed
above rate*

*(Signature)
07/03/23*

TERMS AND CONDITIONS FOR SALE

PRICES: All prices quoted are ex-works Godown, Gurgaon subject to force-de-majeure for goods inunpacked condition.

GOODS & SERVICE TAX: extra @18% GST as applicable as on date.

HSN CODE: 8428

PAYMENT: 100% advance against Proforma invoice prior to dispatch through NEFT / RTGS.

FREIGHT:TO PAY extra actual.

Bank details are mentioned below.

ACCOUNT NAME: GARGI MHE SOLUTIONS, ACCOUNT NO.: 402605000465, BANKERS NAME:
ICICI BANK, BRANCH: SECTOR 74 A ,GURGAON, IFSC CODE: ICIC0004026

INSPECTION: At our works, at your cost.

VALIDITY: 30 days from the date of this offer.

Should you require further any information after receiving this communication, please feel free to write to us in details, our accumulated experience is at your service without any obligation.

Thanking You,

for **GARGI MHE SOLUTIONS**

9871909126

Our Detailed Offer for Manual Scissor Lift Table for Consideration- Jindal- Bhiwadi

Varjax Ravi <ravi.shanker@vanjax.com>

Mon 2/20/2023 12:40 PM

To: Bhiwadi Purchase <purchase.bhiwadi@jindalaluminium.com>

Cc: Rajgopal C. Sarda <rajgopal@jindalaluminium.com>

Dear Purchase, Bhiwadi

Enquiry No.: EN221202832, Dated : 23.12.2022

This is with reference to your above Enquiry which was received by us on 19.02.2023, please find our Offer for the Hydaruailcally Operated Portable Scissor Lift, for your Consideration.

Model : VXLT- 800/1500 Hydaulcally Operated Scissor Lift Table ✓

Capacity : 800 Kgs

Min. Height : 445 mm

Max. Height : 1500 mm

Platform Size : 1220 X 610 mm

Operation : Foot Pedal

Movement : Manual

Refer to attached Catalogue for other Specification.

swivel wheel operable
Ex. 86040/-

Our Price for the above is Rs.95,600/- + GST + P&F + Freight would be Charged Extra

Delivery : Ex. Stock subject to Prior Sale

Payment : 100% in Advance against Proforma Prior to dispatch

Warranty : 12 Months

Validity : 30 Days

Regards,

Ravishanker

Consultant- Marketing (KARNATAKA)

VANJAX SALES PVT. LTD.,

S.No. 230/11, Mevalur Kuppam, Sriperumbudur, CHENNAI- 602 105.

Mobile: +91 95389 93100 : e-Mail: ravi.shanker@vanjax.com : Website: www.vanjax.in

Service over Sales, Honor over Hustle, People over Profits

CHECK LIST	
DISCOUNT	Rate as above
PRICE BASIS	: FOR BHIWADI Ex works
P & F	: INCL ✓ / EXTRA —
GST/IGST	: IGT: 18% Extra
DELIVERY	: 10 days
PAYMENT	: 100% within 7 days from the date of receipt of no
WARRANTY	: One year from the date of receipt
VALIDITY	: —
CHECKED BY	: Rajgopal

Discussed with Mr. Ravishanker and agreed above

(Signature)
07/03/23



VANJAX UNIT -1 (VXC-1)

VANJAX

ISO 9001:2008 COMPANY



VANJAX FACTORY UNIT -2 (VXC-2)

INDUSTRIAL HYDRAULICS - TOOLS - EQUIPMENT - DEVICES - MACHINES

VANJAX MATERIAL HANDLING EQUIPMENT

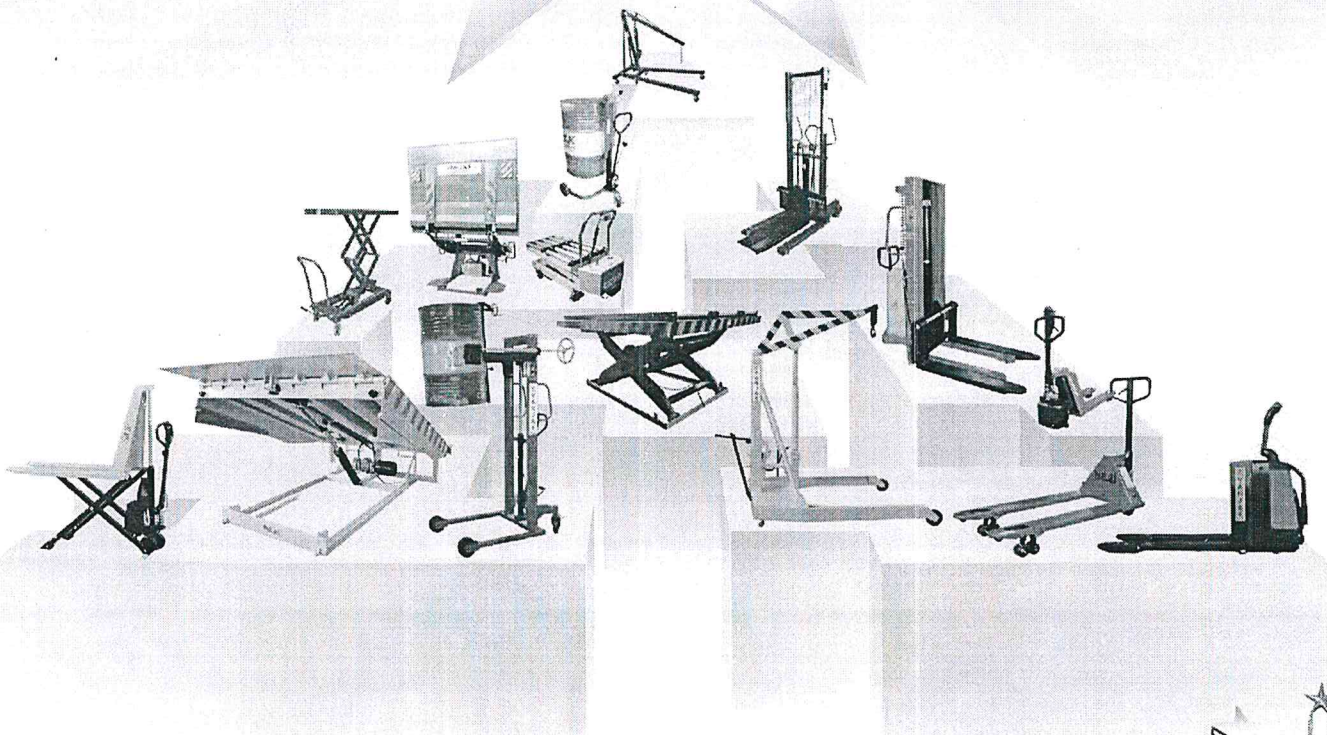
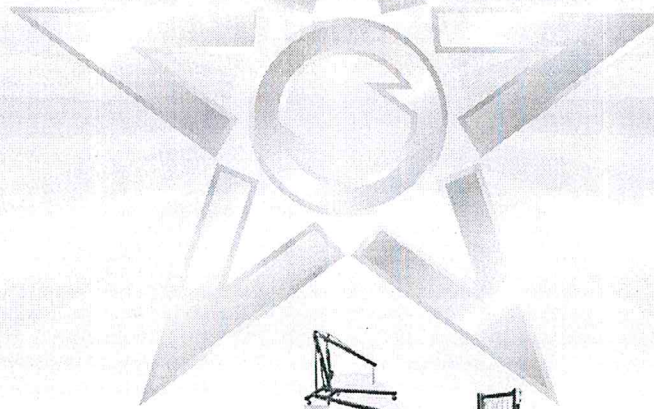

VANJAX SALES PVT. LTD.,
an ISO 9001:2008 COMPANY
Phone: 044-4282 1000, 2625 5300
Fax: 0091-44-4598 5700

Regd. Off. Unit-1 (VXC-1)
343, Sidco Industrial Estate
Ambattur
Chennai 600098. T.N., India

Vanjax Factory Unit-2 (VXC-2)
S.No.230/11, Mevalur Kuppam
Sriperumbudur
Chennai 602105. T.N., India

Vanjax Regional Mktg. Off.
A-53, Ground Floor
Okhla Indl. Area, Phase II
New Delhi 110020. India

e-Mail: info@vanjax.com / cgm@vanjax.com / salesnd@vanjax.com / salesblr@vanjax.com / website: www.vanjax.in

HYDRAULIC POWER IN ACTION ★ YOU NEED IT, VANJAX MAKES IT.



ENTREPRENEUR OF THE YEAR SVE-2012
BANK OF INDIA SPONSORED SURVEY OF 100 BEST SVE-2012

HYDRAULIC PALLET TRUCK



VANJAX SALES PVT. LTD.,
an ISO 9001:2008 COMPANY

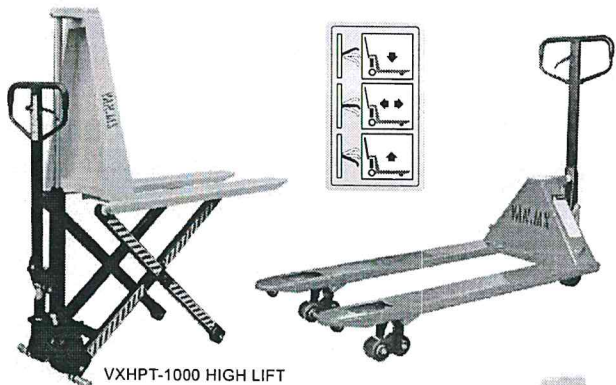

VXHT-1000 HIGH LIFT



VXHPTSE-1000 HIGH LIFT



NEW ECONOMY MODEL

VXHPTE-20-WOP- WITHOUT PLATFORM

TYPE (MANUAL)	VXHS - 1000 /1500	VXHS - 1000 /3000	VXHS - 2000 /1600
CAPACITY	: 1000 kgs	: 1000 kgs	: 2000 kgs
LIFTING HEIGHT	: 1500 mm	: 3000 mm	: 1600 mm
CLOSED HEIGHT	: 81 mm	: 80 mm	: 80 mm
FORK LENGTH	: 930 mm	: 900 mm	: 1000 mm
FORK WIDTH	: 150 mm	: 140 mm	: 300-820 mm
LOAD CENTRE	: 400 mm	: 450 mm	: 400 mm
OVERALL (L x W x H)	: 1410x780x1965 mm	: 1500x800x2060 mm	: 1500x865x2100 mm
NET WEIGHT	: 120 kgs	: 330 kgs	: 285 kgs

TYPE (SEMI-ELECTRIC)	VXHSE-1500/2000	VXHSE-2000/2000	VXHSE-1000/2000
CAPACITY	: 1500 kgs	: 2000 kgs	: 1000 kgs
LIFTING HEIGHT	: 2000 mm	: 2000 mm	: 2000 mm
CLOSED HEIGHT	: 90 mm	: 90 mm	: 90 mm
FORK LENGTH x WIDTH	: 1000 x300-850mm	: 1000 x300-850mm	: 1000 x300-850mm
LOAD CENTRE	: 400 mm	: 400 mm	: 400 mm
MIN. TURNING RADIUS	: 1350 mm	: 1350 mm	: 1350 mm
LIFTING MOTOR	: 12 / 1.5-1.6 kw	: 12 / 1.5-1.6 kw	: 12 / 1.5-1.6 kw
BATTERY	: 12 v / 15 A	: 12 v / 15 A	: 12 v / 15 A
OVERALL (L x W x H)	: 1660x865x1580mm	: 1660x865x1580mm	: 1660x865x1580mm
NET WEIGHT	: 448 kgs	: 460 kgs	: 424 kgs

TYPE (MANUAL)	VXHPT-2500PU	VXHPT-3000PU	VXHPT-3500PU	VXHPT-1000 HL
CAPACITY	: 2500 kgs	: 3000 kgs	: 3500 kgs	: 1000 kgs
WIDTH OF FORKS	: 160 mm	: 160 mm	: 160 mm	: 150 mm
WIDTH BETWEEN FORKS	: 220 / 365mm	: 230 mm	: 230 mm	: 260 mm
OVERALL FORK WIDTH	: 540 / 685mm	: 550 mm	: 550 mm	: 560 mm
OVERALL LENGTH	: 1490 mm	: 1550 mm	: 1550 mm	: 1490 mm
FORK LENGTH	: 1100 mm	: 1150 mm	: 1150 mm	: 1190 mm
MIN. HEIGHT OF FORKS	: 90 mm	: 85 mm	: 85 mm	: 85 ± 2 mm
MAX. HEIGHT OF FORKS	: 200 mm	: 200 mm	: 195 mm	: 800 mm
NET WEIGHT (approx.)	: 72 kgs	: 73 kgs	: 86 kgs	: 128 kgs

* Also available S.S. Pallet Truck 2 Ton. Cap. & 2 Ton. Cap. with weighing scale. Also available with Nylon / Cast-Iron wheels.

TYPE (SEMI-ELECTRIC)	VXHPTSE- 1300	VXHPTSE- 1000 HL
CAPACITY	: 1300 kgs	: 1000 kgs
WIDTH OF FORKS	: 160 mm	: 150 / 160 mm
OVERALL FORK WIDTH	: 540 mm	: 560 mm
OVERALL LENGTH	: 1635 mm	: 1490
FORK LENGTH	: 1150 mm	: 1190 mm
MIN. HEIGHT OF FORKS	: 85 / 75 mm	: 85 ± 2 mm
MAX. HEIGHT OF FORKS	: 120 mm	: 800 mm
BATTERY VOLTAGE, NORMAL CAP.	: 2 x 12 V / Ah	: 70 / 12 Ah / V
NET WEIGHT (approx.) Including Battery	: 155 / 165 kgs	: 159 kgs without Battery

TYPE (FULLY ELECTRIC)	VXHPTSE-1.5 W	VXHPTSE-20-WOP
CAPACITY	: 1500 kgs	: 2000 kgs
FORK, LOWERED HEIGHT	: 85 mm	: 85 mm
OVERALL LENGTH	: 1600 mm	: 1865 x 1935 mm
OVERALL WIDTH	: 560 mm	: 730 mm
aisle WIDTH FOR PALLETS-CROSSWAYS	: 1779 mm	: 1856 mm
aisle WIDTH FOR PALLETS-LENGTHWAYS	: 1929 mm	: 2069 mm
TRAVEL SPEED LOAD / WITHOUT LOAD	: 3.5 / 4 km/h	: 7.5 / 8.5 km/h
BATTERY VOLTAGE, NORMAL CAP.	: 24 v / 60 Ah	: 24 v / 210 Ah
NET WEIGHT (INCLUDING BATTERY)	: 225 kgs(approx)	: 645 kgs (approx)

HYDRAULIC STACKER



Also available
VXHSE-1500/2500
VXHSE-1500/3000
VXHSE-1500/3500
VXHSE-1000/3000
VXHSE-1000/3500

HYDRAULIC STACKER

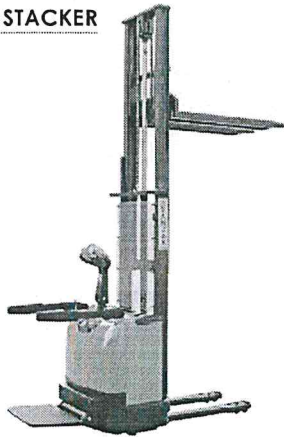

VANJAX SALES PVT. LTD.,
an ISO 9001:2008 COMPANY



TYPE (FULLY ELECTRIC)	: VXHS- 1000 / 2500 FE	: VXHS- 1500 / 2500 FE
CAPACITY	: 1000 kgs	: 1500 kgs
LIFTING HEIGHT	: 2500 mm	: 2500 mm
HANDLE HEIGHT	: 1385 - 1405 mm	: 1385 - 1405 mm
FORK LENGTH x WIDTH	: 1125 mm x 570 mm	: 1125 mm x 570 mm
LOAD CENTRE	: 500 mm	: 400 mm
MIN. TURNING RADIUS	: 1700 mm	: 1750 mm
DRIVING, LIFTING MOTOR	: 24v/2.4 kw, 24v/2-3 kw	: 24v/2.4 kw, 24v/2-3 kw
BATTERY	: 24 v / 240 - 270 Ah	: 24 v / 240 - 270 Ah
OVERALL (L x W x H)	: 2040 x 856 x 1770 mm	: 2040 x 856 x 1770 mm
NET WEIGHT (approx.)	: 858 kgs	: 888 kgs

Also available
VXHS-1000/3000 FE
VXHS-1000/3500 FE
VXHS-1500/3000 FE
VXHS-1500/3500 FE
VXHS-2000/2500 FE

HYDRAULIC BARREL LIFTER & TILTER

TYPE	: VXHBLT - 350
RATED CAPACITY	: 350kgs
LIFTING HEIGHT	: 1425 mm
OVERALL LENGTH	: 1190 mm
OVERALL WIDTH	: 890 mm
OVERALL HEIGHT	: 2020 mm
NET WEIGHT (approx.)	: 155 kgs

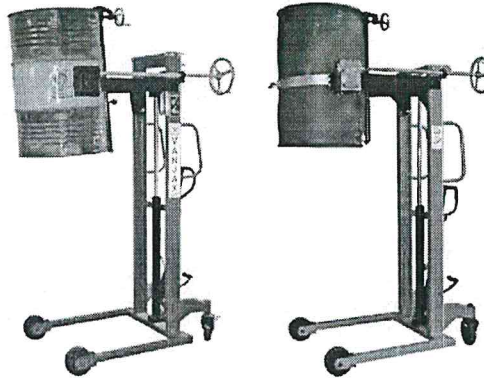

Also available



DRUM LIFTER ATTACHMENT
Cap. -250 kgs.

HYDRAULIC DRUM HANDLER



DRUM HANDLER CUM LOADER -VXDH/L-300

TYPE	: VXDH-250	: VXDH/L-300
LIFTING CAPACITY	: 250 kgs	: 300 kgs
LIFTING HEIGHT	: 280 mm	: 900 mm
MAXIMUM DRUM DIAMETER	: 572 mm	: 572 mm
MAXIMUM DRUM LENGTH	: 915 mm	: 915 mm
NET WEIGHT (approx.)	: 40 kgs	: 120 kgs

HYDRAULIC SCISSOR TRUCK

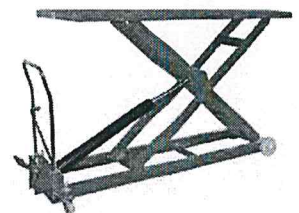

TYPE	: VXLT-500/880	: VXLT-750/900	: VXLT-800/1500	: VXLT-1000/1300	: VXLT-1000/1200
CAPACITY	: 500 kgs	: 750 kgs	: 800 kgs	: 1000 kgs	: 1000 kgs
MINIMUM HEIGHT	: 285 mm	: 420 mm	: 445 mm	: 300 mm	: 425 mm
MAXIMUM HEIGHT	: 880 mm	: 900 mm	: 1500 mm	: 1300 mm	: 1225 mm
PLATFORM SIZE (mm)	: 850x500x50	: 1000x510x55	: 1220x610 mm	: 2035x750 mm	: 1200x800 mm
MODE OF OPERATION	: FOOT PEDAL	: FOOT PEDAL	: FOOT PEDAL	: FOOT PEDAL	: FOOT PEDAL
MOVEMENT	: MANUAL	: MANUAL	: MANUAL	: MANUAL	: MANUAL
SAFETY FEATURE	: MECH. LOCK Wheel Brake	: MECH. LOCK Wheel Brake	: MECH. LOCK Wheel Brake	: MECH. LOCK Wheel Brake	: MECH. LOCK Wheel Brake
NET WEIGHT (approx.)	: 81 kgs.	: 120 kgs.	: 195 kgs.	: 198 kgs.	: 163 kgs.

TYPE (WITH ROLLERS)	: VXLT - 2500
CAPACITY	: 2500 kgs
MINIMUM HEIGHT	: 500 mm
MAXIMUM HEIGHT	: 1700 mm
PLATFORM SIZE (mm)	: 2000 x 2600
BAZE FRAME SIZE	: 1900 x 2510
LIFT SPEED	: 60 ~ 70 sec
POWER PACK	: 380v / 50 hz, AC 2.2 kw
NET WEIGHT (approx.)	: 1700 kgs.

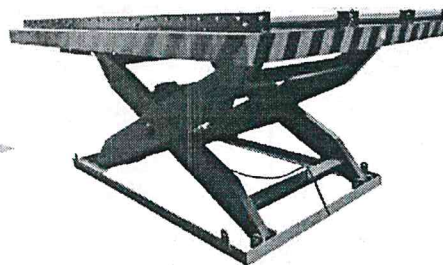

Design / Dimensions are subject to change for sake of progressive improvement.
Warranty / Guarantee upto one year from the date of purchase.

HYDRAULIC DOCK LEVELER

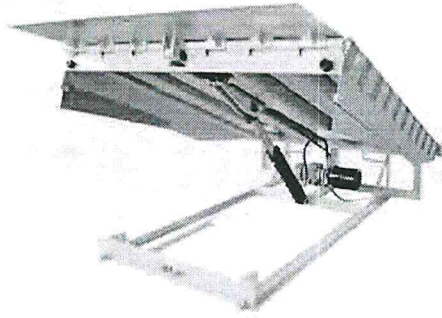

TYPE (LIGHT DUTY)	: VXFC - 31001	: VXFC - 32001
CAPACITY	: 1000 kgs	: 2000 kgs
LENGTH	: 1550 mm	: 1740 mm
WIDTH	: 900 mm	: 950 mm
HEIGHT	: 1505 mm	: 1475 mm
NET WEIGHT (approx.)	: 84 kgs	: 96 kgs

CAP. IN KGS	LOAD IN KGS				E1	H	H1	H2	H3	H4	h1	h2	h3	h4
	W1	W2	W3	W4										
1000	1000	750	500	250	130	165	1790	1875	2000	2100	500	380	260	140
2000	2000	1500	1000	500	180	185	2020	2135	2265	2400	500	355	210	60

TYPE (HEAVY DUTY)	: VXFC - 2000	: VXFC - 3000	: VXFC - 5000
CAPACITY	: 2000 kgs	: 3000 kgs	: 5000 kgs
LENGTH	: 2200 mm	: 2360 mm	: 3360 mm
WIDTH	: 1170 mm	: 1544 mm	: 1830 mm
HEIGHT	: 2060 mm	: 2060 mm	: 3700 mm

CAP. IN KGS	LOAD IN KGS				E1	H	H1	H2	H3	H4	h1	h2	h3	h4
	W1	W2	W3	W4										
2000	2000	1200	600	400	350	250	3100	3400	3700	4000	1020	880	740	600
3000	3000	1900	1000	700	350	325	3100	3400	3700	4000	1020	880	740	600
5000	5000	1400	700	575	400	430	4500	5300	5700	6100	1330	900	750	500

HYDRAULIC TAIL LIFT

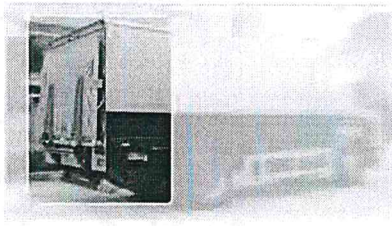

TYPE	: VXLT - with Rollers	: VXLT - with Balls
CAPACITY	:	:
MINIMUM HEIGHT	:	:
MAXIMUM HEIGHT	:	:
PLATFORM SIZE (mm)	:	:
BASE FRAME SIZE	:	:
LIFT SPEED	:	:
POWER PACK	:	:

CUSTOMER TO SPECIFY



VANJAX SALES PVT. LTD.,
an ISO 9001:2008 COMPANY



TYPE	: VXDL - 9	: VXDL - 12
CAPACITY	: 9000 kgs	: 12000 kgs
PLATFORM SIZE	: 2500 x 2000 mm	: 2500 x 2000 mm
LIP BOARD WIDTH	: 450 mm	: 450 mm
TRAVEL	UP	: 300 mm
	DOWN	: 300 mm
PIT SIZE - L x W x Depth (rear)	: 2700 x 2060 x 485 mm	: 2700 x 2060 x 600 mm
MOTOR	: 2 hp	: 2 hp
NET WEIGHT (approx.)	: 1100 kgs	: 1200 kgs

HYDRAULIC FLOOR CRANES

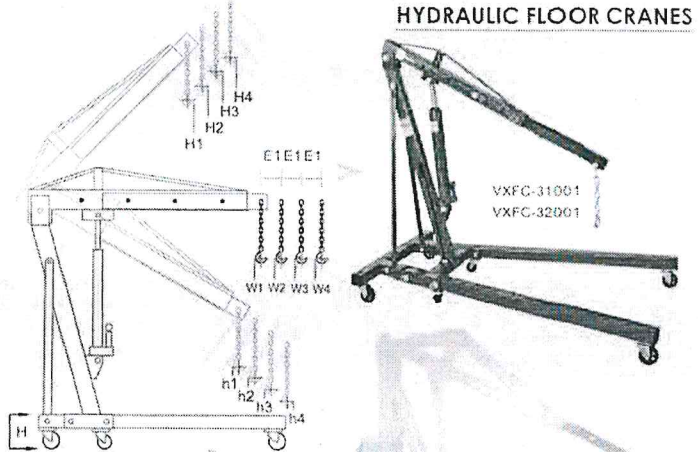

AVAILABLE BATTERY OPERATED WITH TRACTION

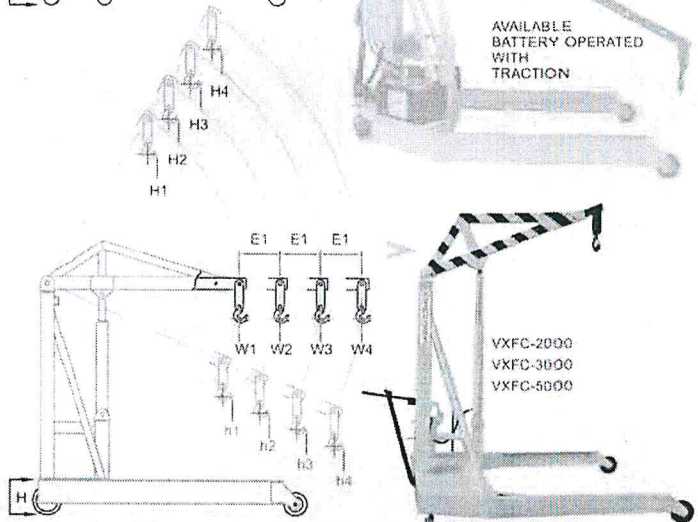

TYPE (Automatic Mechanical Tilting System)	: VXHTL - 2000 / 1500 SP
CAPACITY	: 2000 kgs
HEIGHT	: 1550 mm
VOLTAGE	: 12 V / 24 DC
CENTRE OF THE GRAVITY OF THE LOAD	: 600 mm
STANDARD PLATFORM WIDTH	: 1800-2000-2300-2440 mm
STANDARD PLATFORM HEIGHT	: 1650-1800-2000 mm
NET WEIGHT (approx.)	: 530 kgs.

CUSTOMISED SCISSOR LIFTS WITH ROLLERS / BALLS AVAILABLE IN ALL CAPACITIES

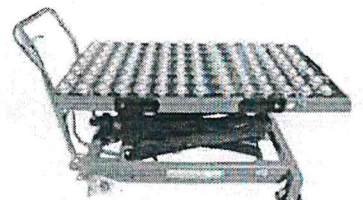

This photo literature is the sole property of VANJAX SALES (P) Ltd, Chennai. Issued for legitimate information purposes in connection with our business only. Entrusted to the recipient in good faith & trust as a confidential document protected by exclusive copyright as an intellectual property with sole proprietary rights vested in VANJAX SALES (P) Ltd, India.

DEALERSHIP / AGENT ENQUIRIES INVITED