

PART NO-1

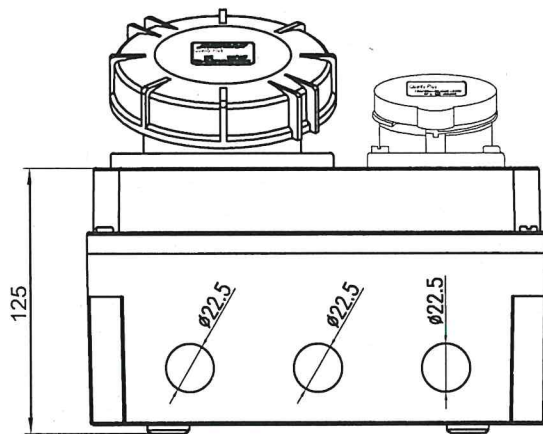

S.No.	DESCRIPTION	MODEL	QTY	REMARKS
1	Junction Box	JEPJB 265	1	MADE OF 16/18 SWG CRCA SHEET POWDER COATED
2	63A - 5 Pin Angular Socket IP - 67	J635AS IP - 67	1	MADE OF ENGINEERING MAT'L-STANDARD UNBREAKABLE MATERIAL AND FULLY INSULATED
3	16A - 3 Pin Angular Socket IP - 44	J203AS IP - 44	1	MADE OF ENGINEERING MAT'L STANDARD UNBREAKABLE MATERIAL AND FULLY INSULATED
4	Provision for 4 Pole MCB 1No. 1 Pole MCB 1No.			BOX WILL BE SUPPLIED WITHOUT MCB
5	Ultra Bright LED Module Indicating light	φ16.5	3	MADE OF NYLON6 KGV4

JINDAL ALUMINIUM LTD.
 SP-2/333, INDUSTRIAL AREA,
 BHIWADI, RAJASTHAN-301019

	NAME	DATE
DRN.	VIKAS	09.11.22
CKD.	<i>[Signature]</i>	10/11/22
APPD.	<i>[Signature]</i>	10/11/22

ALL DIMENSIONS ARE IN mm., UNLESS OTHERWISE SPECIFIED

SCALE
1:1

METAL DISTRIBUTION BOX
FOR WELDING MACHINE

DRAWING NO.
EL-BP-17-A4