

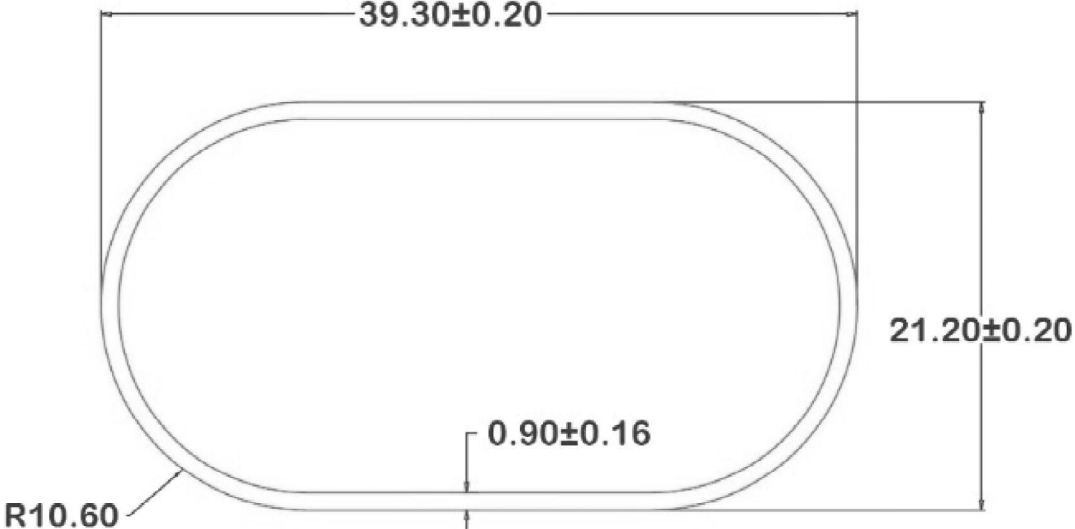
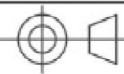

CUSTOMER APPROVAL				 ACTUAL SIZE SCALE 1:1		ANGULARITY +/- 2 Degree.			
COMPANY RUBBER STUMP.	DATE SIGN.								
<p>Weight Range : 580 to 650 gms for 2450 mm length</p> <div style="text-align: center; margin: 10px 0;">   </div> 								TWIST +/- 1 Degree.	
								STRAIGHTNESS +/- 1.7/M.	
								FLATNESS +/- 1.0mm.	
								REV	
								AMMENDMENT NO.	
AREA SQ.MM. 89.98mm	Wt/2450MM 0.595kg	WEIGHT RANGE 0.580-0.650 KG	ALLOY./TEMP. 6063 -T6	DRAWING DATE 05/09/2016	DRAWN BY MOHIT RATHEE	CHECKED BY ANKUR AGGARWAL	APPROVED BY -----		
SCALE 1:1	CCD, M.M.	CUT LENGTH.	Unspecified Tolerances :- ± 0.20 Unspecified radius :- R 0.25			REVISED DATE:- ----			
						REVISED NO:- ----			
CUSTOMER:- Vulcan Extrusions Private Limited						CONCENTRICITY = 0.1 MM OVALITY = 0.20 MM			
 BALAJI ALUMINIUM EXTRUSIONS PVT. LTD. PLOT NO.-109, SECTOR-16,HSIIDC,BAHADURGARH,HARYANA-124507								DRG.NO.	