

✓ (✓)

Ra 25

Ra 25

1922±1

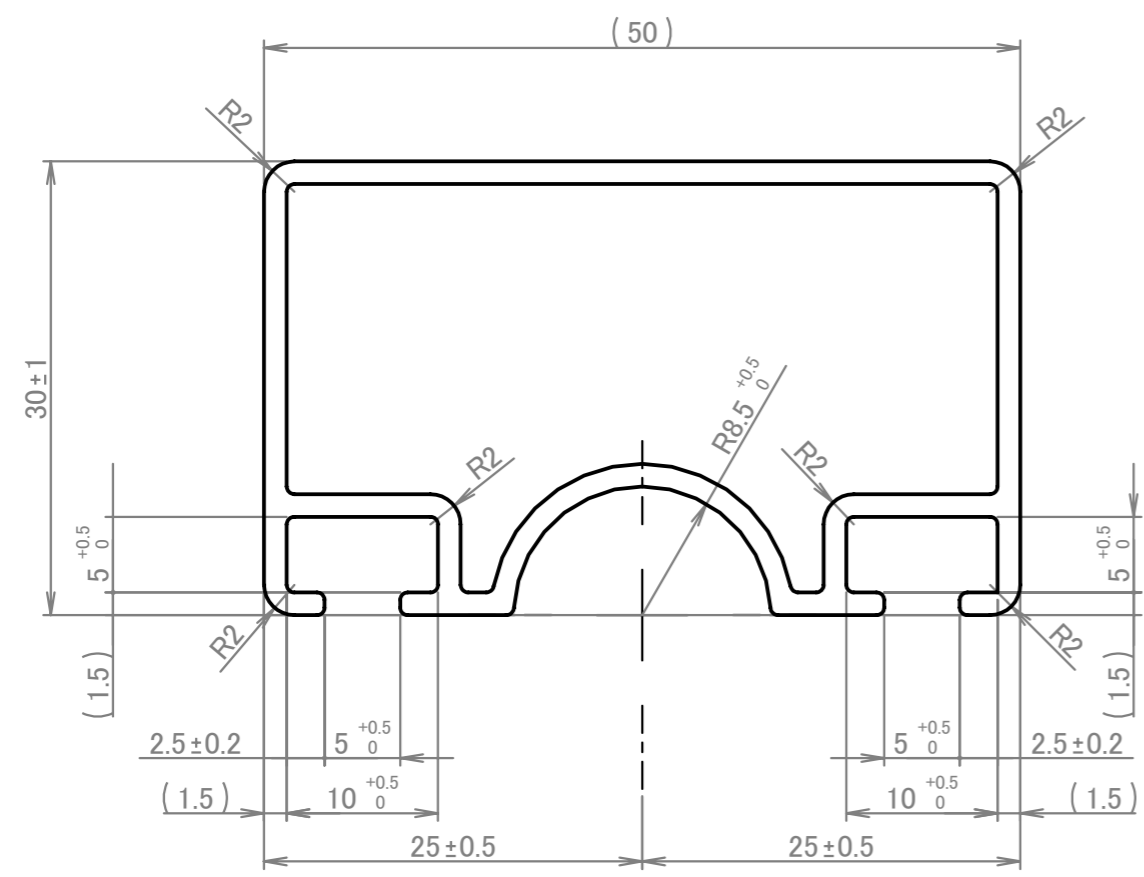
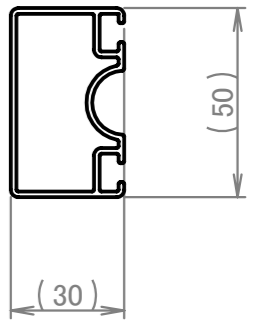

NOTE

- 1.SURFACE TREATMENT:Anodized Aluminum(clear)
- 1.No burr end of side work. And around hole on the top surface.
- 2.Unless no indication of angle,it should be R0.5.
- 3.Unless no indication of thickness,it should be 1.5mm.
- 4.Mode code:P/N.

TOLERANCE

- 1.THICKNESS TOLERANCE : ±0.23mm
- 2.CAMBER : LESS THAN 0.3mm PER IN ANY 300mm LENGTH
- 3.TWIST : LESS THAN 1/2° PER IN ANY 300mm LENGTH
- 4.FLATNESS : LESS THAN 0.15mm PER IN ANY 25mm LENGTH
- 5.ANGLE : ±1°

**CONFIDENTIAL**

1 piece/1 machine

5						MATERIAL	A6N01-T6	MASS	1423.41	
4						IMPORTANCE	C	SCALE	1:2	
3							APPROVED	JAGATJIT SINGH		
2							CHECKED	JAGATJIT SINGH		
1							DRAWN	PARMINDER SINGH		
MARK	DATE	REVISION NO.	LOCATION	DRAWN	CHECKED	DATE	2023. 02. 07	T. NO.	P2302830-00	
GENERAL TOLERANCE						TITLE	BOOM PIPE			
REMARK						BOOM PIPE				
SURFACE TREATMENT : Anodized Aluminum(clear)						DRAWING NO.	P2302830		VER.	00
REMOVE BURRS AND SHARP EDGES.										

DATE IS WRITTEN AS "YYYY. MM. DD"

IMPORTANCE A: Important safety part B: Important function part C: General function part D: General part

JAGATSUKH INDUSTRIES PVT LTD