

# Q00006

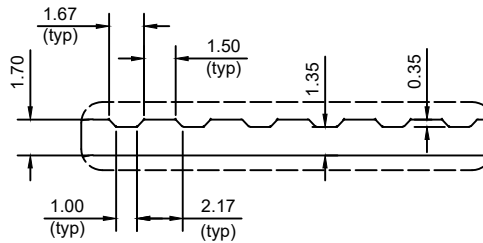
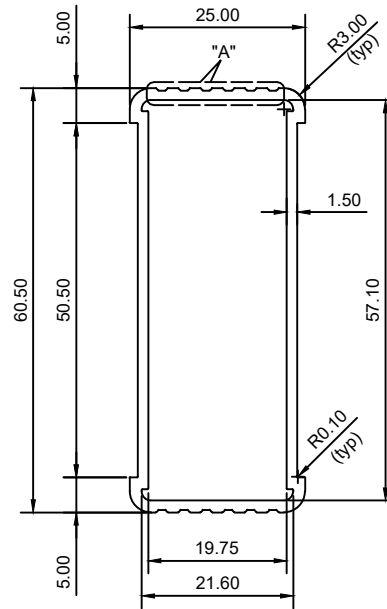

**DETAIL "A"**  
1:3

GENERAL TOLERANCE: UNLESS OTHERWISE SPECIFIED. ALL DIMENSIONS ARE IN MM. X - ±0.1      ANGLES - ±1°      125 XX - ±0.01      SURFACE FINISH - XXX - ±0.001		BREAK ALL SHARP EDGES AND REMOVE BURRS  CHAMFER FIRST THREAD ON TAPPED HOLES		<u>DISCLAIMER:</u> THE INFORMATION DATA AND DRAWINGS EMBODIED IN THIS DOCUMENT ARE STRICTLY CONFIDENTIAL AND ARE SUPPLIED WITH THE UNDERSTANDING THAT THEY WILL NOT BE DISCLOSED TO THIRD PARTIES WITHOUT PRIOR CONSENT OF MTANDT LIMITED. COPYRIGHT MTANDT ALL RIGHTS RESERVED		DRAWN: DD CHECKED: VSK APPROVED: GM DATE: 16-02-2022		ISSUE STATUS: FABRICATION TITLE: EX001 SIZE: A4      DWG NO: MTT/EX/000001 SCALE: 1:1      REV.:00      SHEET: 1 OF 1	
THIRD ANGLE PROJECTION 		MATERIAL: ALUMINIUM 6063  WEIGHT:							