

D

C

B

A

BILL OF MATERIAL

ITEM	DESCRIPTION	MATERIAL	QTY.	PART NO
1	AL BRACKET	6082T6	1	1301288

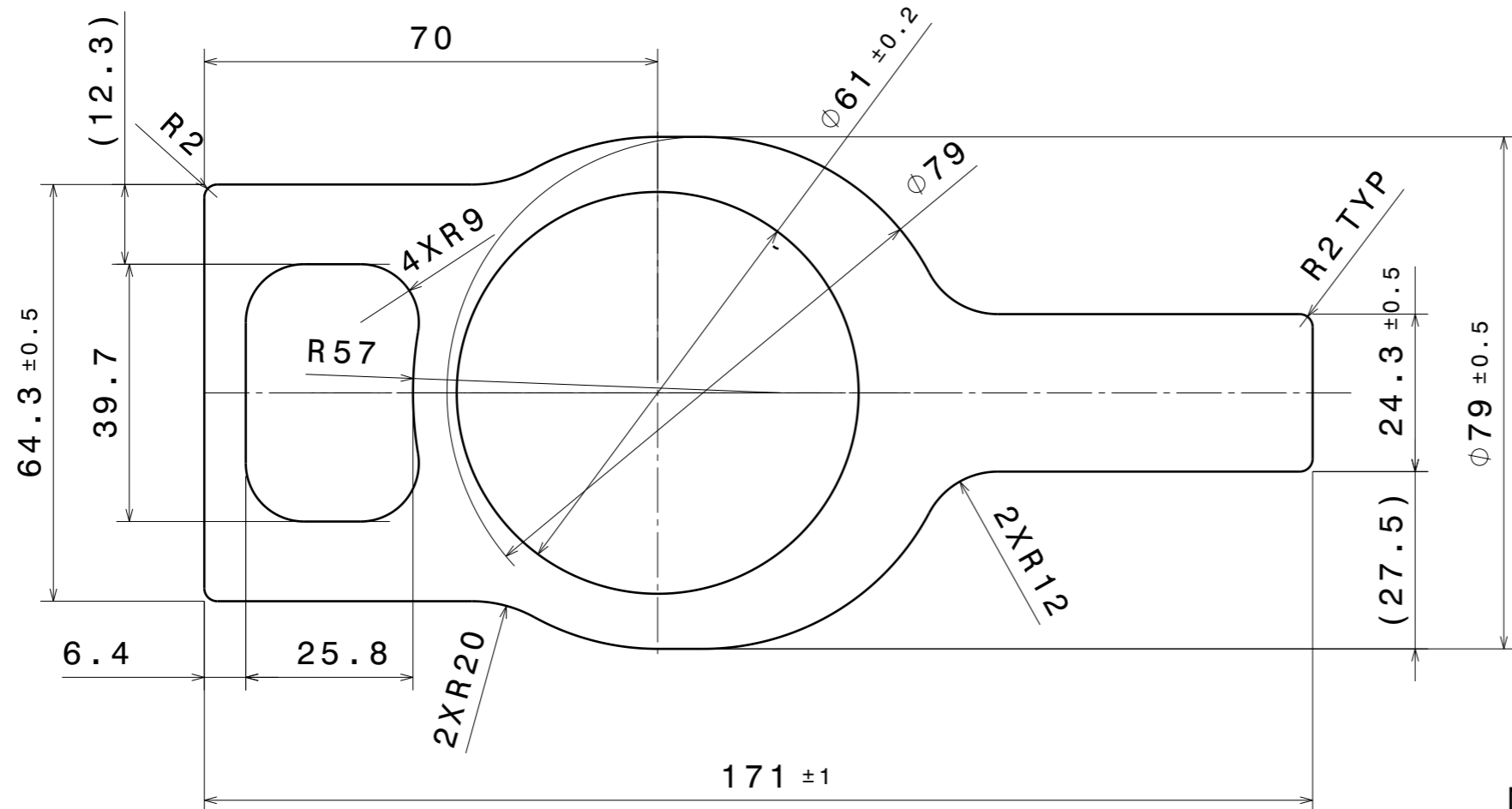
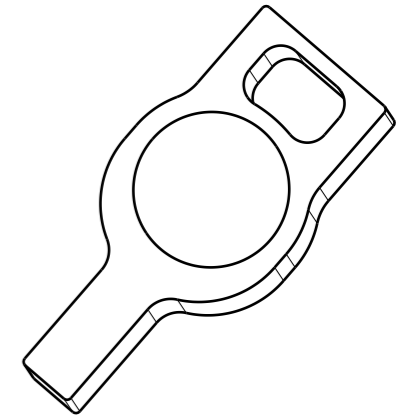

NOTE:
 1) FOR MORE DIM. REFER TO 3D MODEL.
 2) PART SHOULD BE FREE FROM BURR, DENT, SCRATCH AND CUT MARKES.

Unspecified tolerances as per ISO 2768-mk						All dimensions in mm unless otherwise stated.	Special Characteristic Symbol	Safety Related	Key Fit & Function	
Dimensions	≤ 6	>6 & ≤30	>30 & ≤120	>120 & ≤400	>400 & ≤1000					
Metal	±0.1	±0.2	±0.3	±0.5	±0.8	±1.2	Do not scale drawing	●	▲	0
DRN	VIJAY 18.03.2024									
CHD										
APD	BALBIR									
SIZE	A4									
SCALE	NTS	WEIGHT (gms)	693	PART NUMBER	1301288	FINAL CODE	1003706			
The information contained in this document is property of Stork Rubber Product Pvt Ltd. It is not to be shared or reproduced without permission.										
REV NO.		DATE	18.03.2024	REVISION DETAIL			ECN NO	DRN BY	APPD BY	

D

A