

BILL OF MATERIAL				
ITEM	DESCRIPTION	MATERIAL	QTY	PART NO
1	AL BRACKET MACHINED	6082T6	1	1301287

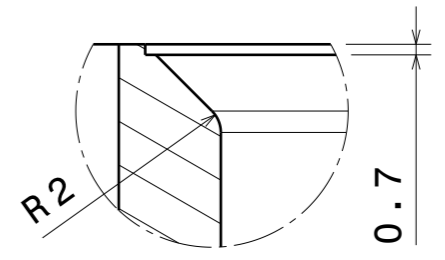
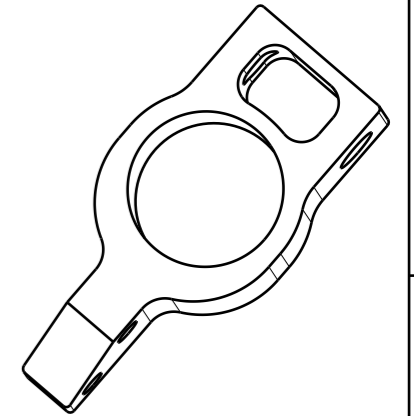

Detail B
Scale: 2:1

NOTE:
 1) FOR MORE DIM. REFER TO .3D MODEL.
 2) PART SHOULD BE FREE FROM BURR, DENT, SCRATCH AND CUT MARKES.

Unspecified tolerances as per ISO 2768-mk						All dimensions in mm unless otherwise stated.		Special Characteristic Symbol	Safety Related	Key Fit & Function		
Dimensions	≤ 6	>6 & ≤30	>30 & ≤120	>120 & ≤400	>400 & ≤1000	>1000	Do not scale drawing					
Metal	±0.1	±0.2	±0.3	±0.5	±0.8	±1.2						0
DRN	VIJAY 18.03.2024	 Stork Rubber Products Pvt Ltd					E					
CHD	OPN						D					
APD	BALBIR						C					
SIZE	A4	DESCRIPTION AL BRACKET MACHINED					B					
SCALE	NTS	WEIGHT (gms) 624	PART NUMBER 1301287	FINAL CODE 1003706		A	18.03.2024	INITIAL REVISION				
REV NO.		DATE	REVISION DETAIL				ECN NO	DRN BY	APPD BY			

The information contained in this document is property of Stork Rubber Product Pvt Ltd. It is not to be shared or reproduced without permission.