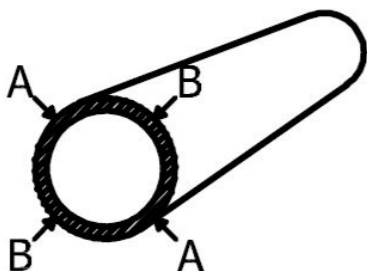
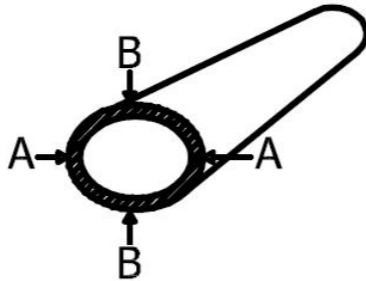
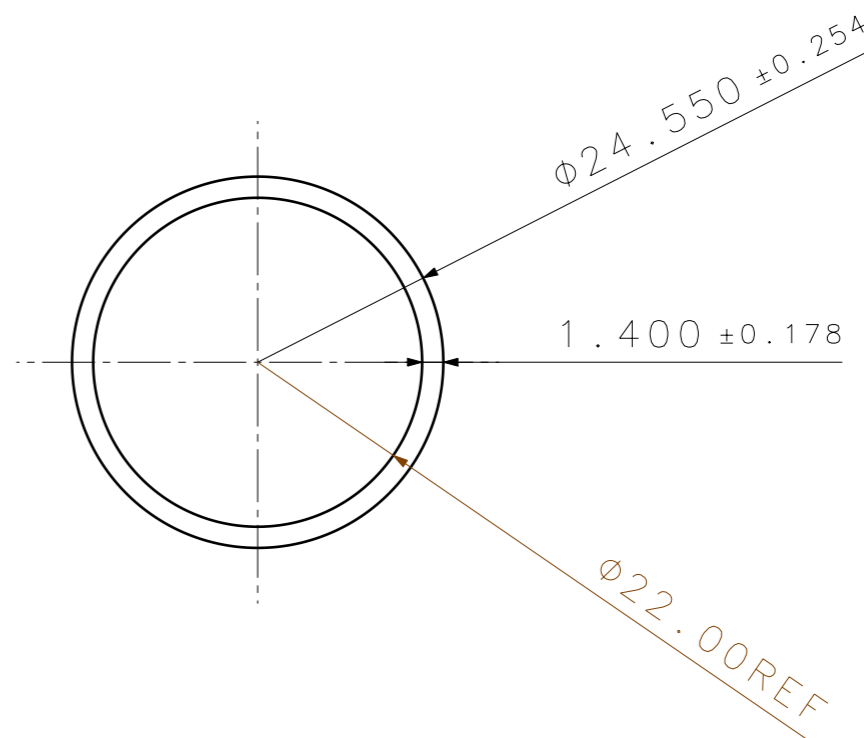

TABLE 12.2 Diameter-Round tube

Tolerance - mm. plus and minus

SPECIFIED DIAMETER (mm)	ALLOWABLE DEVIATION OF MEAN DIAMETER FROM SPECIFIED DIAMETER (Size)  Difference between 1/2 (AA+BB) and specified diameter	ALLOWABLE DEVIATION OF DIAMETER AT ANY POINT FROM SPECIFIED DIAMETER  Difference between AA or BB and specified diameter
	COL. 1	COL. 2
12.7-25.37	0.254	0.508
25.4-50.77	0.304	0.635
50.8-101.57	0.381	0.762

TOLERANCE STANDARD
STRAIGHTNESS: 1mm / m

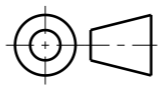

FRONT VIEW
SCALE: 2:1

GENERATED FROM: 3D	THIRD ANGLE PROJECTION 	TOL UNLESS SPECIFIED 0 & 1 PLC DEC: ± N/A 2 PLC DEC: ± N/A ANGLES: ± N/A	DOC NO: N892628-C2D1
SHEET: 2 OF 2		ALL DIMENSIONS mm SIZE: A3 REF SCALE: 1:1	TITLE: UPPER POLE CST92 TYPE 03 REVISION: *** VER/ITER: *** CHANGE: FOR PART DATA REFER TO PART DETAILS REPORT
