

DO NOT SCALE DRAWING

1st ANGLE

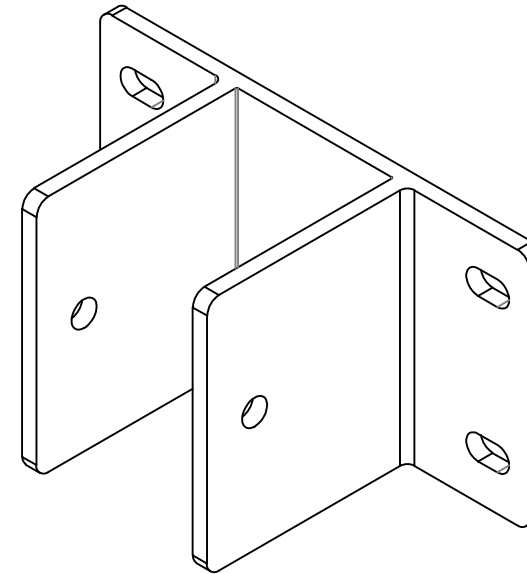

Q00027

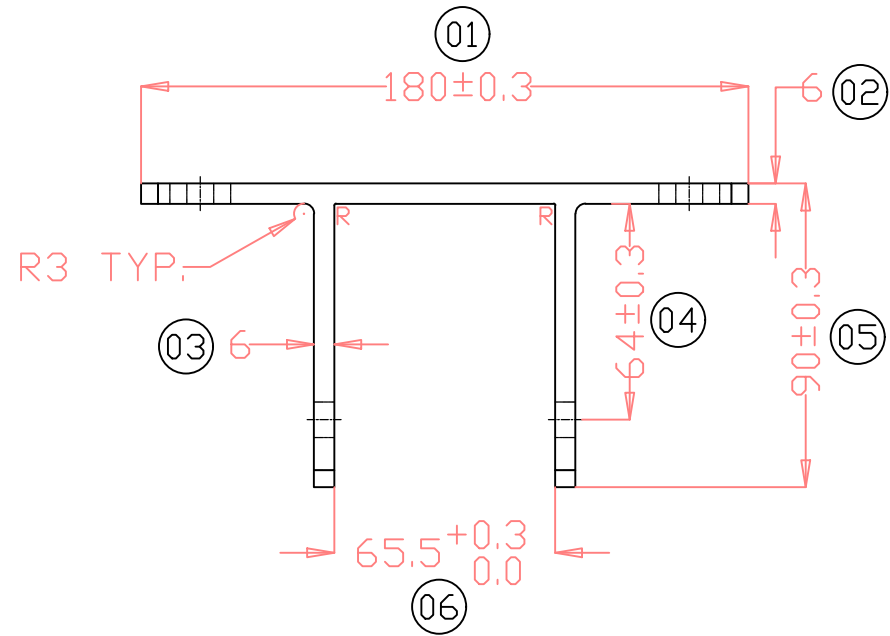
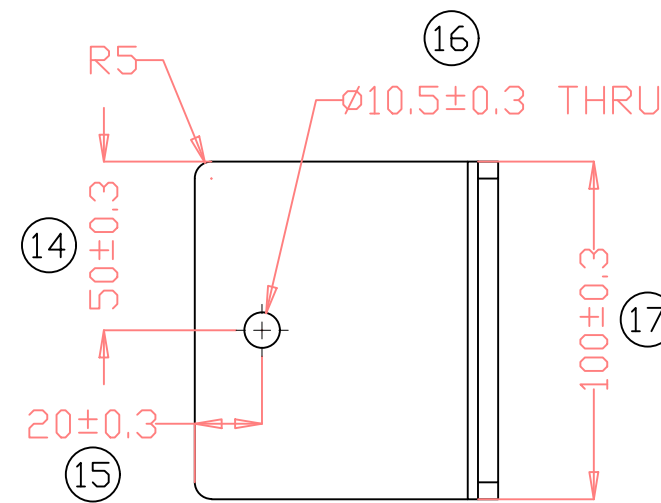
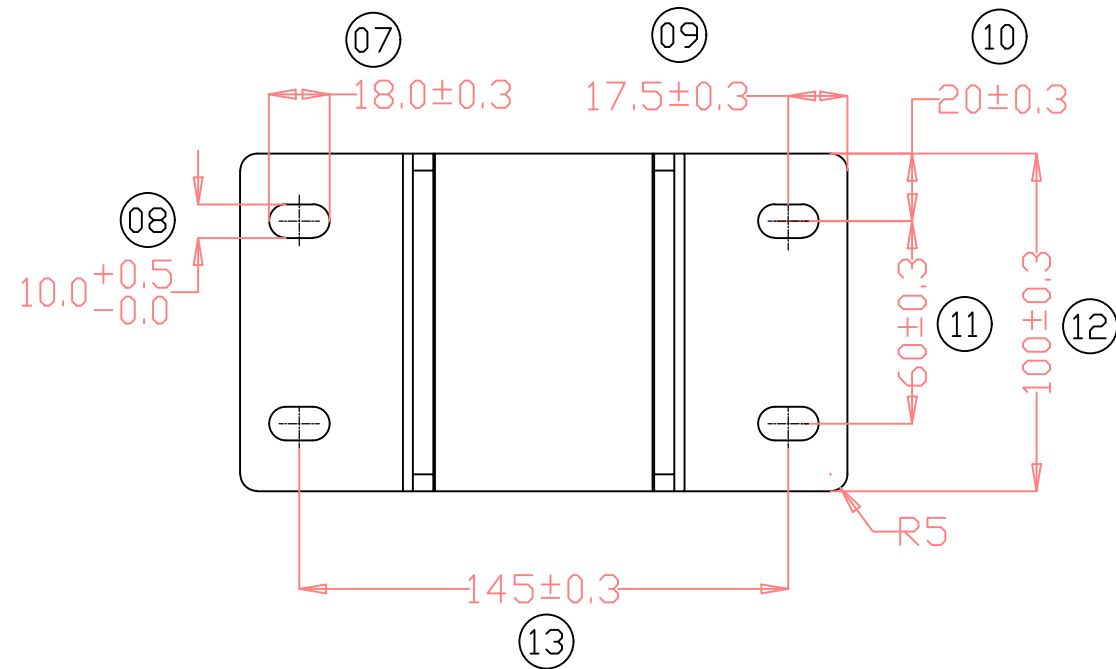

Revision made by	Revision details:		-	
Description. FACADE CURTAIN WALL BRACKET FOR F65				
Material	M.S.	Specification	EN 12608:2003	
Colour / Finish	-	-	-	-
Area (flexible)	-	I xx value	-	Unspecified tolerance ±0.3 mm
Weight (flexible)	1.59 kg	I yy value	-	Unspecified radii R 0.5 mm
Area (rigid)	-	V dimension	-	Unspecified radii r 0.3 mm
Weight (rigid)	-	Outer wall thickness	6.0±0.2 mm	Drawn by SS
Total area	-	Main wall thickness	-	Drawing date 2022.05.10
Total Weight (MGW)	-	Inner wall thickness	-	Drawing issue A
Length	-	Angular tolerance	90°±0.5°	Part Number EIAAUC007
Scale 1:1	-	Concave/convex	0.3 mm	

ENCRAFT India Pvt. Ltd

© This drawing is the intellectual property of ENCRAFT India Pvt. Ltd and shall not be copied without written consent.

Form NO. FD-4005