

BEFORE APPROVAL CHECK ALL DIMENSIONS PROPERLY

PROPOSED DRAWING

Q00526

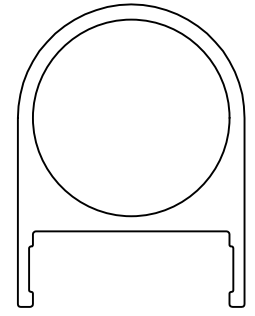

SCALE 1:1

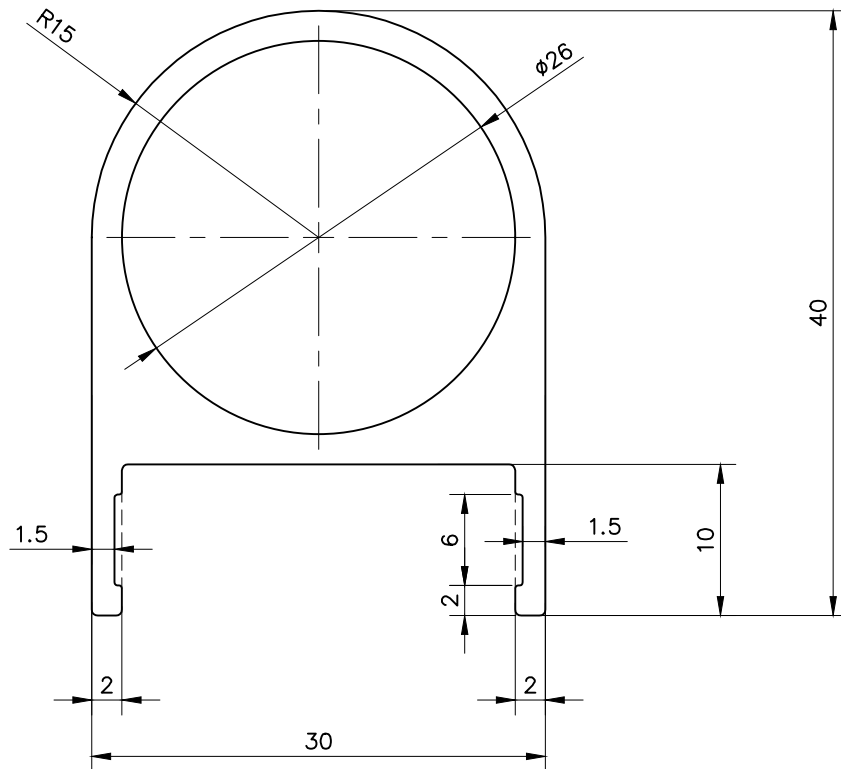

- 1. STRAIGHTNESS= 1.7mm/M
- 2. TWIST= 1.7mm/M
- 3. ANGULARITY=  $\pm 2^\circ$
- 4. FLATNESS= 0.007xWIDTH

UNCONTROLLED COPY

1) THE WELDING LINE IN THE EXPOSED SURFACE OF PROFILE IS UNAVOIDABLE. 2) PLEASE SPECIFY IMPORTANT SIZES. 3) PLEASE SPECIFY IF THIS PROFILE MATCHES WITH OTHER PROFILES. 4) PLEASE SPECIFY EXPOSED SURFACE. OTHERWISE CONSIDERED AS NO EXPOSED SURFACE. 5) FINISH :-  MILL FINISH /  ANODIZING /  POWDER COATING



SYMBOL OF QUALITY  
AN ISO 9001 COMPANY

**JINDAL ALUMINIUM LTD.**

BHIWADI-301019 (INDIA)

	NAME	DATE
DRAWN	ASHUTOSH	12-04-2023
CHECKED		
APPROVED		

- 1. ALL DIMENSIONS ARE IN mm.
- 2. ROUND OFF ALL SHARP CORNERS WITH 0.40 mm.
- 3. TOLERANCES WILL BE AS PER BS:EN-755-9 , UNLESS OTHERWISE SPECIFIED

SCALE	1:1&2:1
AREA mm <sup>2</sup>	306.43
PERIMETER mm.	147.41
WEIGHT kg/m	0.827
DRAWING No.	SECTION No.

PARTY'S NAME	M/s. JSL LIFE STYLE LTD.
PARTY'S DRAWING No.	AS PER DRAWING -AAB63147 (Q00526)
ALLOY & TEMPER	63400 WP
DESCRIPTION	MISC. TUBE