

© COPYRIGHT THIS DRAWING AND DESIGN REMAINS THE PROPERTY OF JINDAL ARCHITECTURE LTD. AND MAY NOT BE COPIED WITHOUT PRIOR WRITTEN APPROVAL FROM THIS COMPANY.

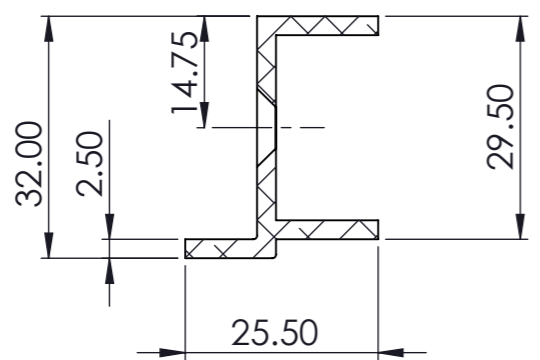
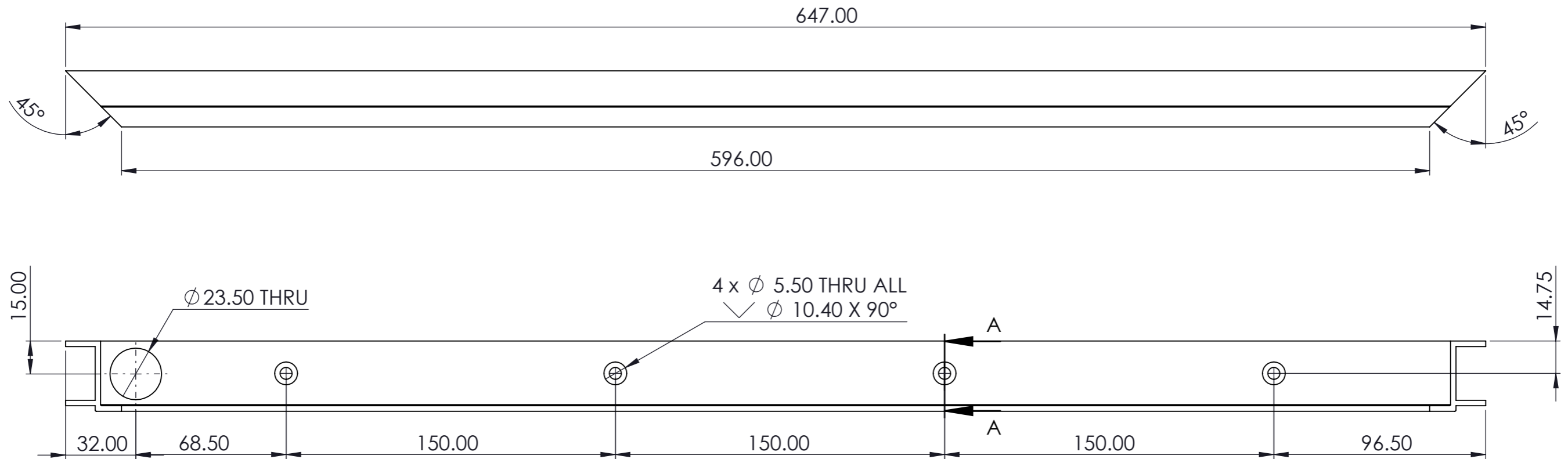

SECTION A-A
SCALE 1 : 1

		arc JSL		PART DRG. NO.:																																																																																												
		JSL LIFE STYLE LTD.		AAB63136 RH																																																																																												
		PROJECT DISCRPTION:	STATUS: L3	REV. No.	DESCRIPTION: AL EXTRUSION																																																																																											
		Wt.(Kg)-		BLANK SIZE: XX																																																																																												
		MATERIAL: AL		FINISH:																																																																																												
		DRAWN BY:		CHECKED BY:																																																																																												
		DATE :- 29-11-2019		DATE :																																																																																												
		CONTROLLED COPY MASTER COPY		SHEET SCALE- 1:2																																																																																												
		SHEET- 1 OF 1		SHEET SIZE: A3 LAYOUT: LANDSCAPE																																																																																												
<table border="1"> <thead> <tr> <th rowspan="2">SYMBOL</th> <th rowspan="2">REVISION DESCRIPTION</th> <th rowspan="2">SIGNATURE</th> <th rowspan="2">DATE</th> </tr> </thead> <tbody> <tr> <td> </td> <td> </td> <td> </td> <td> </td> </tr> </tbody> </table>		SYMBOL	REVISION DESCRIPTION	SIGNATURE	DATE					<table border="1"> <thead> <tr> <th colspan="8">GEN. TOLERANCE CHART</th> <th colspan="8">ANGULAR DIMENSIONS</th> </tr> <tr> <th colspan="8">LINEAR DIMENSIONS</th> <th colspan="2">UPTO 10</th> <th colspan="2">OVER 10 TO 50</th> <th colspan="2">OVER 50 TO 120</th> <th colspan="2">OVER 120</th> </tr> <tr> <th>ABOVE</th> <th>0.5</th> <th>3</th> <th>6</th> <th>30</th> <th>120</th> <th>315</th> <th>1000</th> <th>DEGREE</th> <th>MM / 100MM</th> <th>DEGREE</th> <th>MM / 100MM</th> <th>DEGREE</th> <th>MM / 100MM</th> <th>DEGREE</th> <th>MM / 100MM</th> </tr> </thead> <tbody> <tr> <td>UPTO & INCLUDING</td> <td>3</td> <td>6</td> <td>30</td> <td>120</td> <td>315</td> <td>1000</td> <td>ABOVE</td> <td>1°</td> <td>±1.8</td> <td>±30'</td> <td>±0.9</td> <td>±20'</td> <td>±0.6</td> <td>±10'</td> <td>±0.3</td> </tr> <tr> <td>DEVIATION</td> <td>±0.1</td> <td>±0.1</td> <td>±0.2</td> <td>±0.5</td> <td>±0.8</td> <td>±1.0</td> <td>±2.0</td> <td></td> <td></td> <td></td> <td></td> <td></td> <td></td> <td></td> <td></td> </tr> </tbody> </table>		GEN. TOLERANCE CHART								ANGULAR DIMENSIONS								LINEAR DIMENSIONS								UPTO 10		OVER 10 TO 50		OVER 50 TO 120		OVER 120		ABOVE	0.5	3	6	30	120	315	1000	DEGREE	MM / 100MM	DEGREE	MM / 100MM	DEGREE	MM / 100MM	DEGREE	MM / 100MM	UPTO & INCLUDING	3	6	30	120	315	1000	ABOVE	1°	±1.8	±30'	±0.9	±20'	±0.6	±10'	±0.3	DEVIATION	±0.1	±0.1	±0.2	±0.5	±0.8	±1.0	±2.0									<table border="1"> <tr> <td>QUANTITY: NO.</td> <td>APPROVED BY:</td> <td>DATE :</td> </tr> </table>		QUANTITY: NO.	APPROVED BY:	DATE :
SYMBOL	REVISION DESCRIPTION					SIGNATURE	DATE																																																																																									
GEN. TOLERANCE CHART								ANGULAR DIMENSIONS																																																																																								
LINEAR DIMENSIONS								UPTO 10		OVER 10 TO 50		OVER 50 TO 120		OVER 120																																																																																		
ABOVE	0.5	3	6	30	120	315	1000	DEGREE	MM / 100MM	DEGREE	MM / 100MM	DEGREE	MM / 100MM	DEGREE	MM / 100MM																																																																																	
UPTO & INCLUDING	3	6	30	120	315	1000	ABOVE	1°	±1.8	±30'	±0.9	±20'	±0.6	±10'	±0.3																																																																																	
DEVIATION	±0.1	±0.1	±0.2	±0.5	±0.8	±1.0	±2.0																																																																																									
QUANTITY: NO.	APPROVED BY:	DATE :																																																																																														

NOTE :- ALL DIMENSIONS IN MM (UNO).

SCALE: 1:2, Unless Specified

WEIGHT: Grams(Tentative)