

PRESS NO.	DIE SIZE	NO. OF HOLES	MIN. CONT.	EXT. RATIO	ANGULARITY	±2°	CUSTOMER'S APPROVAL
I					FLATNESS	0.007 MM/MM OF WIDTH	
II					TWIST	1.70 MM/M	
III					STRAIGHTNESS	1.70 MM/M	
TYP. WALL THICKNESS UNLESS INDICATED OTHERWISE					MATCHING NO.		END USE
0.50 TYP. RADIUS AT ALL CORNERS UNLESS INDICATED OTHERWISE					o SOLID o SEMI-HOLLOW o HOLLOW		False Ceiling

**Q27883**

NEW Q00037

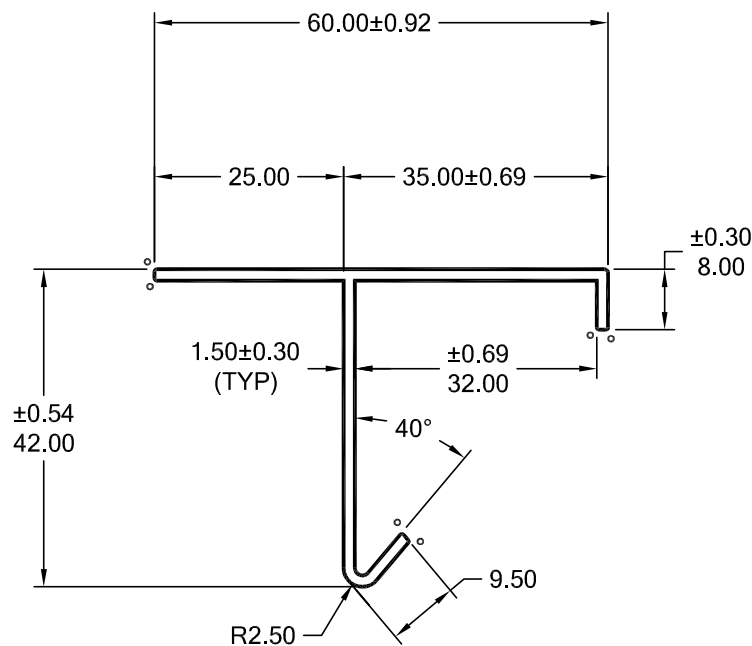

EXCLUSIVE DIE FOR M/S CORUS INDIA PVT LTD; DELHI

o = 0.30R

R E V S I O N	HINDALCO INDUSTRIES LIMITED						ADITYA BIRLA HINDALCO	
	FABRICATION - EXTRUSION & DIESHOP							
	P.O. :- RENUKOOT, DISTT :- SONEBHADRA, UP, INDIA							
	FAX NO. 0091-5446-252107, 252427							
AREA (MM) <sup>2</sup>	WT. (KG/M)	PERIMETER	FACTOR	CCD	SCALE	DATE	DRAWN	CHECKED
173.19	<b>0.469</b>	233.16	497	63	1:1	26.10.2011	J P Sharma	Ramdhani
UNLESS NOTED OTHERWISE ALL DIMENSIONS WILL BE IN ACCORDANCE WITH						ALLOY	CUST's DWG NO. :- KZ-AC-01	
IS : 3965 : 1981 TOLERANCES. "ALL DIMENSIONS ARE IN MM"						6063	DWG. NO. / ENQ. NO. :- I-18262	
CUSTOMER APPROVAL OF DIMENSIONS AND TOLERANCES CONSTITUTE ACCEPTANCE OF MATERIAL WITHIN PRINT						SECTION NO. :- <b>SP-8220</b>		