

BEFORE APPROVAL CHECK ALL DIMENSIONS PROPERLY

PROPOSED DRAWING
Q00537

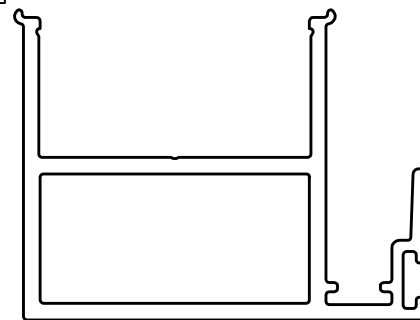

SCALE 1:1

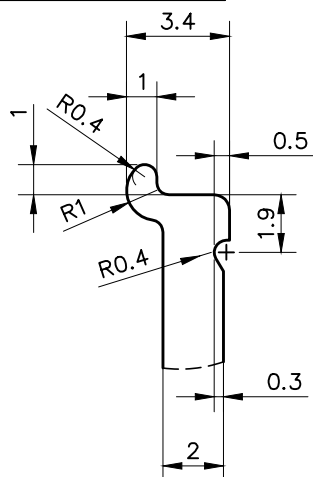

DETAIL A
SCALE 4:1

NOTE:-

r = 0.50 Radius (2 Places)

R= 1.0 Radius (2 Places)

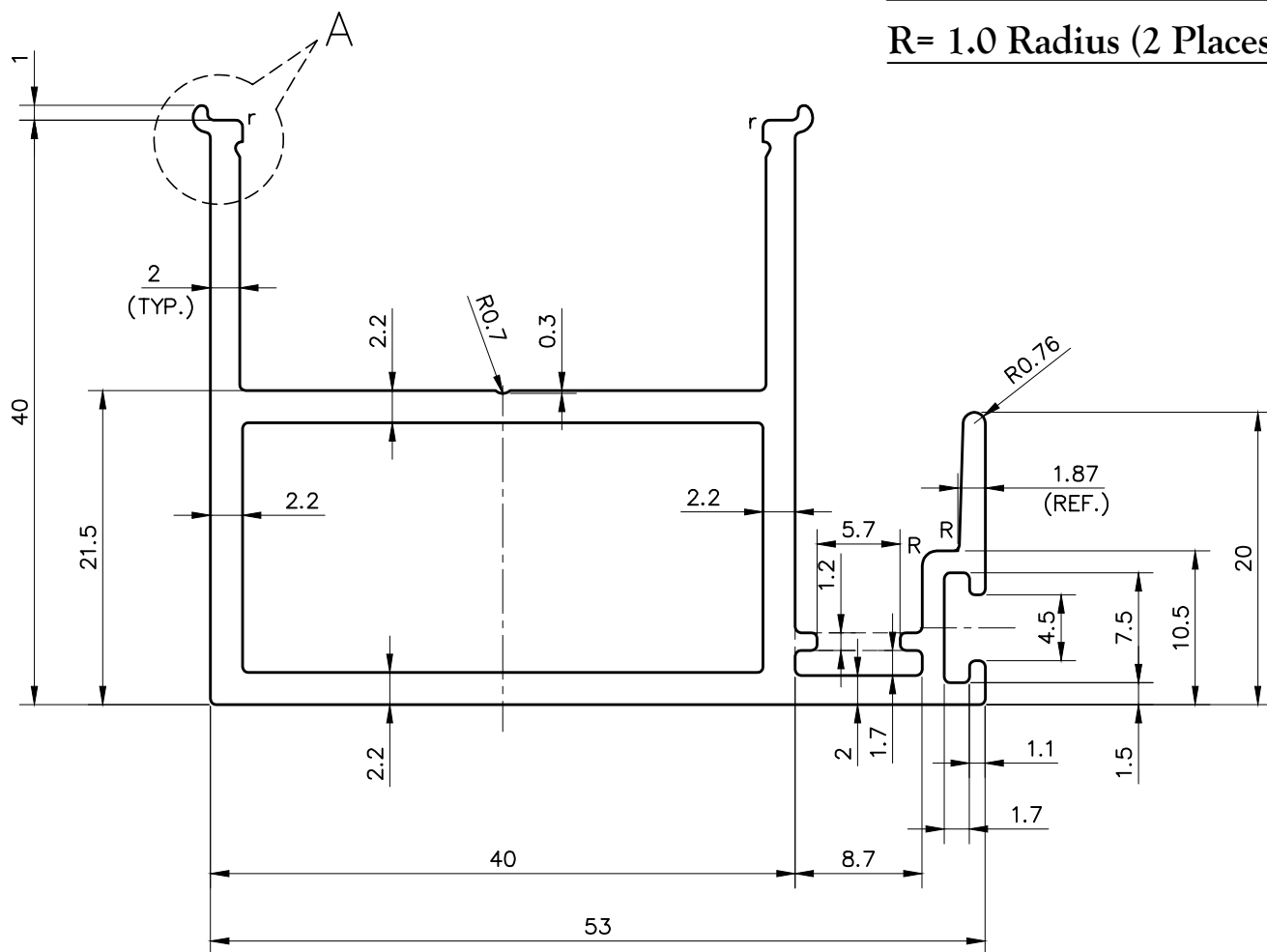

SYMBOL OF QUALITY
AN ISO 9001 COMPANY

JINDAL ALUMINIUM LTD.
BHIWADI-301019 (INDIA)

	NAME	DATE
DRAWN	ASHUTOSH	14-04-2023
CHECKED		
APPROVED		

1. ALL DIMENSIONS ARE IN mm.
2. ROUND OFF ALL SHARP CORNERS WITH 0.40 mm.
3. TOLERANCES WILL BE AS PER BS:EN-755-9 , UNLESS OTHERWISE SPECIFIED

SCALE 1:1,2:1&4:1

AREA mm² 392.52

PERIMETER mm. 278.57

WEIGHT kg/m 1.060

PARTY'S NAME	M/s. SHANKAR FENESTRATIONS & GLASSES (I) PVT. LTD.	DRAWING No.	SECTION No.
PARTY'S DRAWING No.	AS PER DRAWING-DGU INTERLOCK (Q00537)		
ALLOY & TEMPER	6063-T6	-	-
DESCRIPTION	WINDOW SECTION		