

BEFORE APPROVAL CHECK ALL DIMENSIONS PROPERLY

PROPOSED DRAWING

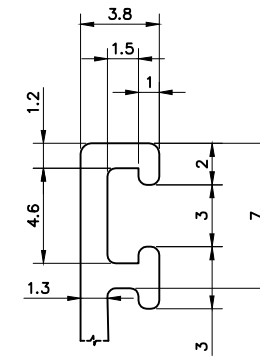

DETAIL A
SCALE 4:1

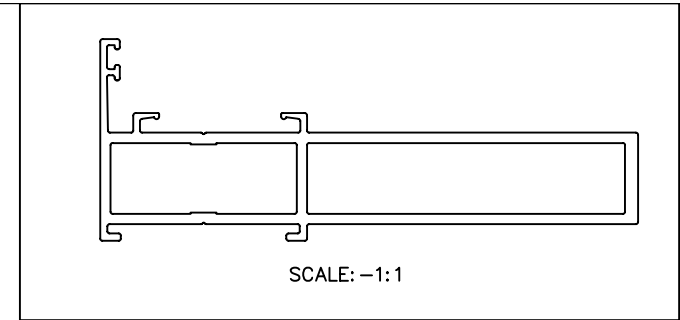
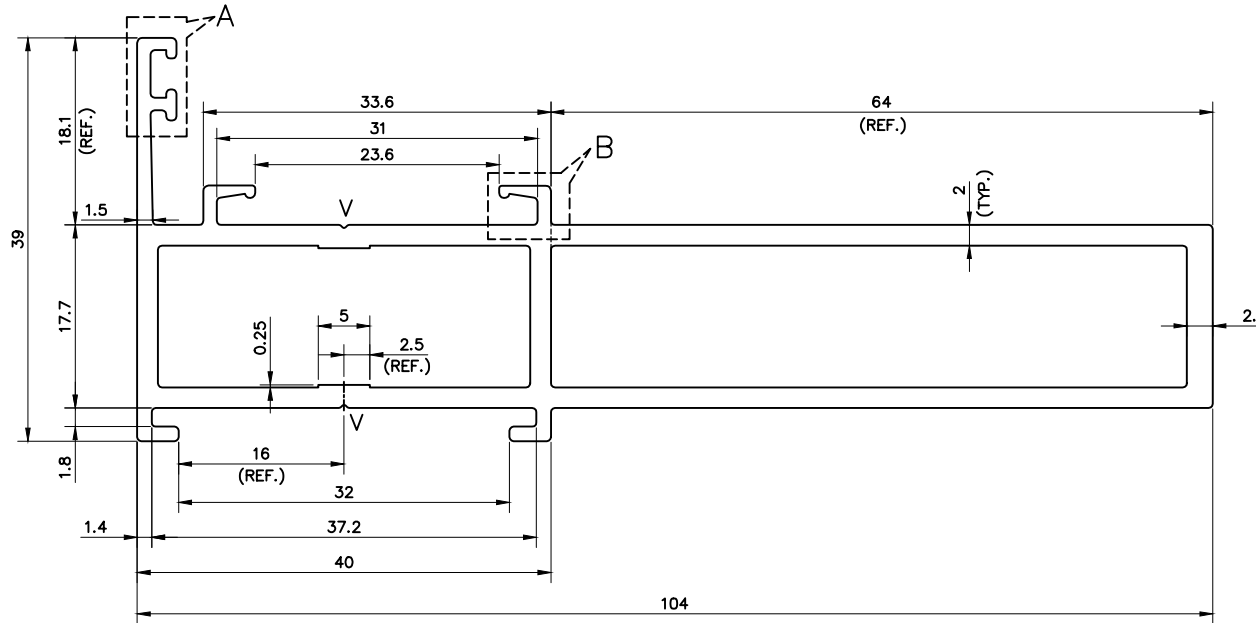
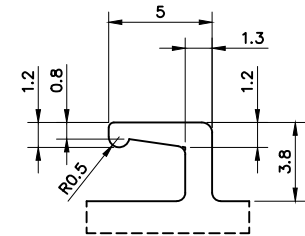

DETAIL B
SCALE 4:1

NOTE:-

$V = 0.30 \times 90^\circ$

- 1) THE WELDING LINE IN THE EXPOSED SURFACE OF PROFILE IS UNAVOIDABLE. 2) PLEASE SPECIFY IMPORTANT SIZES.
3) PLEASE SPECIFY IF THIS PROFILE MATCHES WITH OTHER PROFILES. 4) PLEASE SPECIFY EXPOSED SURFACE. OTHER-
WISE CONSIDERED AS NO EXPOSED SURFACE. 5) FINISH :- MILL FINISH / ANODIZING / POWDER COATING

 SYMBOL OF QUALITY AN ISO 9001 COMPANY	JINDAL ALUMINIUM LTD. BHIWADI-301019 (INDIA)	NAME	DATE
		DRAWN	AMIT 14-04-2023
		CHECKED	
APPROVED			
1. ALL DIMENSIONS ARE IN mm. 2. ROUND OFF ALL SHARP CORNERS WITH 0.40 mm. 3. TOLERANCES WILL BE AS PER BS:EN-755-9, UNLESS OTHERWISE SPECIFIED		SCALE	1:1, 2:1 & 4:1
		AREA mm ²	574.35
		PERIMETER mm.	342.131
PARTY'S NAME	M/s. RG FACADE SOLUTIONS, GHAZIABAD	WEIGHT kg/m	1.551
PARTY'S DRAWING No.	AS PER DRAWING	DRAWING No.	SECTION No.
ALLOY & TEMPER	6063 - T6		
DESCRIPTION	ARCH. MISC.		