

BEFORE APPROVAL CHECK ALL DIMENSIONS PROPERLY

PROPOSED DRAWING

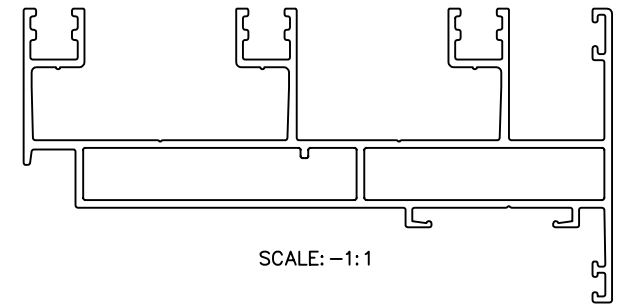

SCALE: -1:1

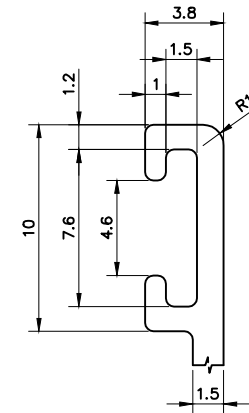
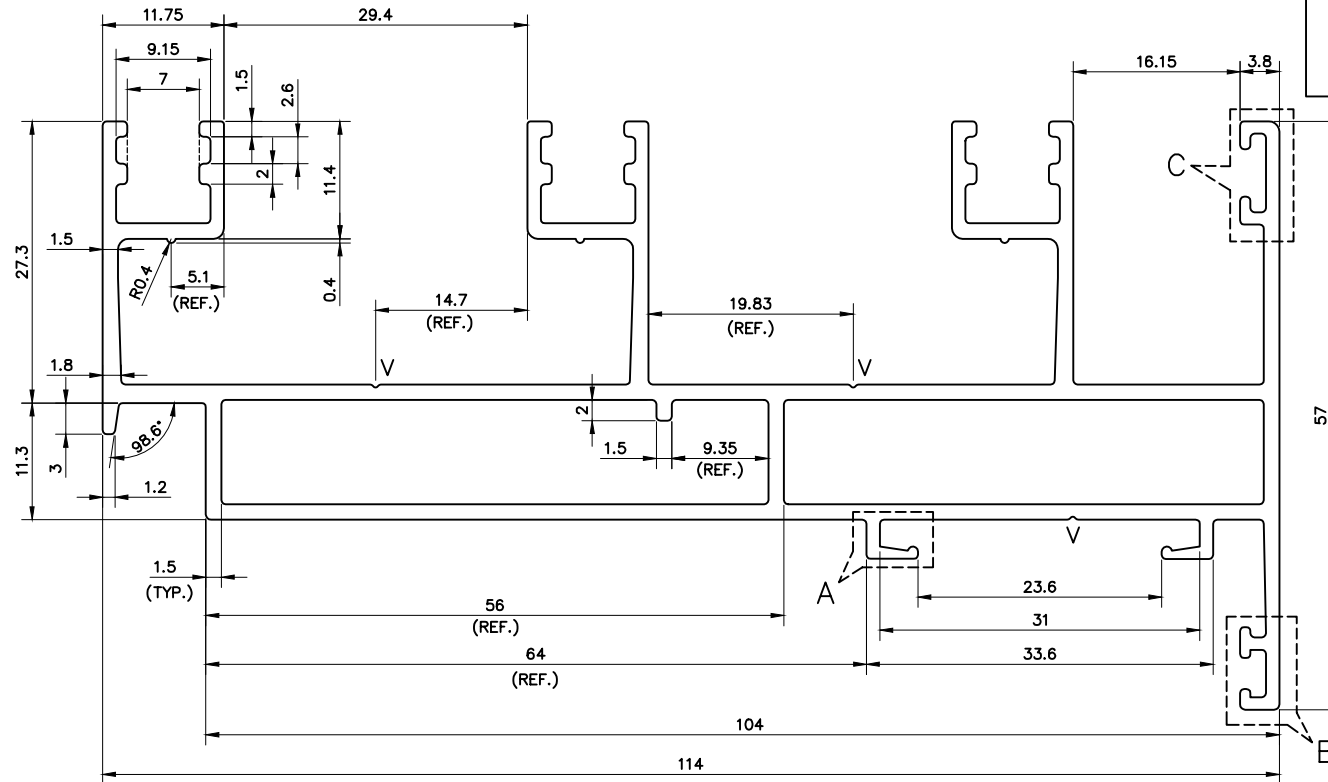

DETAIL C  
SCALE 4:1

NOTE:-

V= 0.30 X 90°

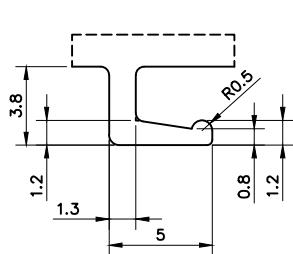

DETAIL A  
SCALE 4:1

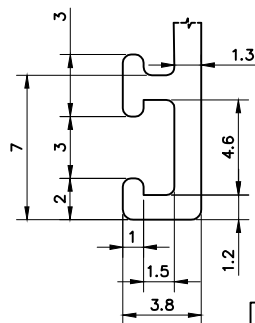

DETAIL B  
SCALE 4:1

- 1) THE WELDING LINE IN THE EXPOSED SURFACE OF PROFILE IS UNAVOIDABLE. 2) PLEASE SPECIFY IMPORTANT SIZES.
- 3) PLEASE SPECIFY IF THIS PROFILE MATCHES WITH OTHER PROFILES. 4) PLEASE SPECIFY EXPOSED SURFACE. OTHER WISE CONSIDERED AS NO EXPOSED SURFACE. 5) FINISH :-  MILL FINISH /  ANODIZING /  POWDER COATING

 SYMBOL OF QUALITY AN ISO 9001 COMPANY	<b>JINDAL ALUMINIUM LTD.</b>		NAME	DATE
	BHIWADI-301019 (INDIA)		DRAWN	AMIT 14-04-2023
			CHECKED	
		APPROVED		
1. ALL DIMENSIONS ARE IN mm. 2. ROUND OFF ALL SHARP CORNERS WITH 0.40 mm. 3. TOLERANCES WILL BE AS PER BS:EN-755-9, UNLESS OTHERWISE SPECIFIED		SCALE	1:1,2:1&4:1	
		AREA mm <sup>2</sup>	699.98	
		PERIMETER mm.	689.385	
		WEIGHT kg/m	1.890	
PARTY'S NAME	M/s. RG FACADE SOLUTIONS, GHAZIABAD	DRAWING No.	SECTION No.	
PARTY'S DRAWING No.	AS PER DRAWING			
ALLOY & TEMPER	6063 - T6			
DESCRIPTION	ARCH. MISC.			