

Q01636
 Q01637
 Q01638
 Q01639
 Q41640
 Q41641
 Q41642
 Q41643

S. No.	Final Size, Extrusion A mm	Wt. of Extruder Section Kg / Running meter
1	L 65 X 125	2.345
2	L 65 X 150	2.600
3	L 65 X 175	2.857
4	L 65 X 200	3.113
5	L 65 X 225	3.370
6	L 65 X 250	3.626
7	L 65 X 275	3.883
8	L 65 X 300	4.141

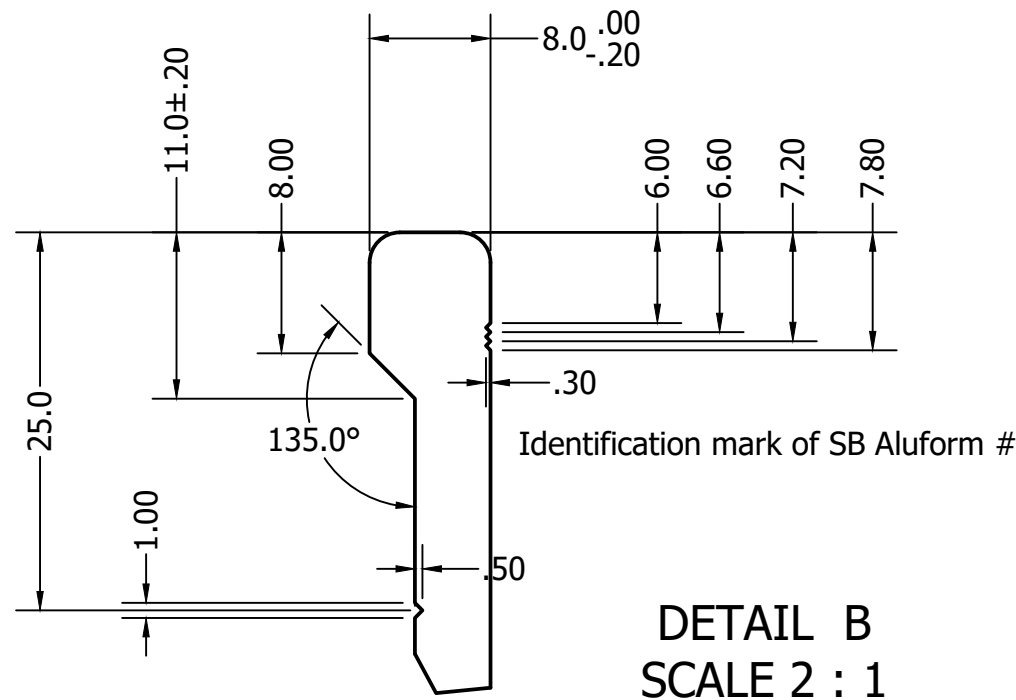
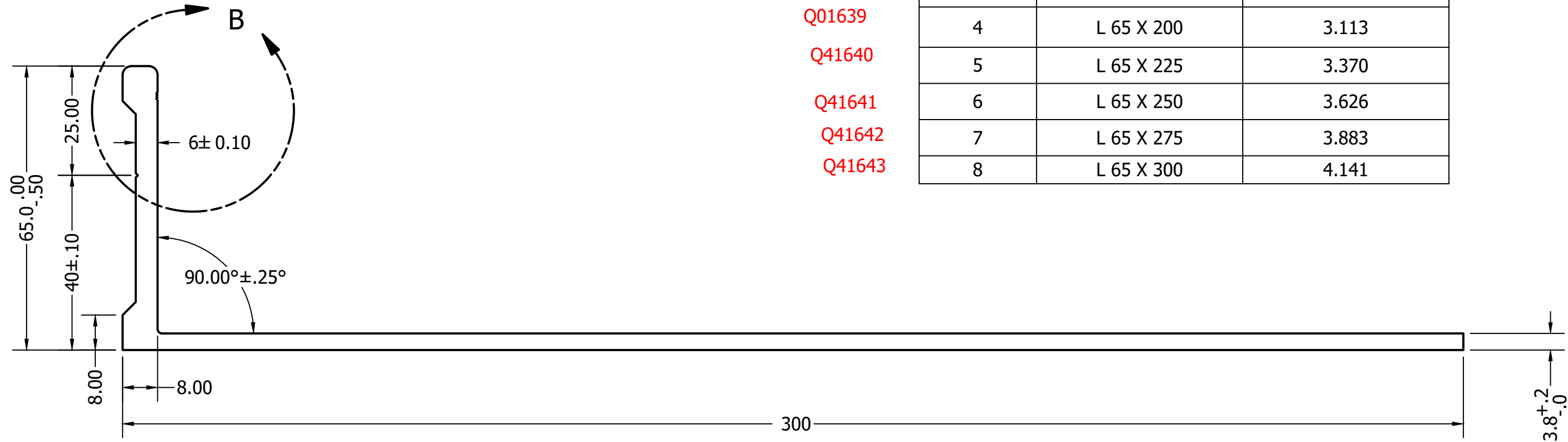

DETAIL B
 SCALE 2 : 1

NOTE -

- 1) All dimensions are in mm.
- 2) Material: Aluminum Alloy 6061 T6, unless otherwise specified.
- 3) All extrusion shall conform to BS-EN 755-9: 2001
- 4) Angular Tolerances $\angle = \pm 0.25^\circ$ Degree
- 5) All extrusion, that will be supplied, shall be with Test Certificate & patrol inspection report.
- 6) **Not to Scale**

REVISION HISTORY				
ZONE	REV	DESCRIPTION	DATE	APPROVED
	R2	1) Exact profile size & wt. added 2) L 125 size added	25-08-2023	

DRAWN SSJ	20-03-2023	M/S SB FORMWORK SYSTEMS (I) PVT. LTD.		
CHECKED		TITLE		
QA		L` Extruded section A x 65 X 1000 mm		
MFG				
APPROVED				
		SIZE A3	DWG NO L Section 65_125 to 300	REV R2
		SCALE 1 : 1	SHEET 1 OF 1	