

BEFORE APPROVAL CHECK ALL DIMENSIONS PROPERLY

PROPOSED DRAWING  
Q00581

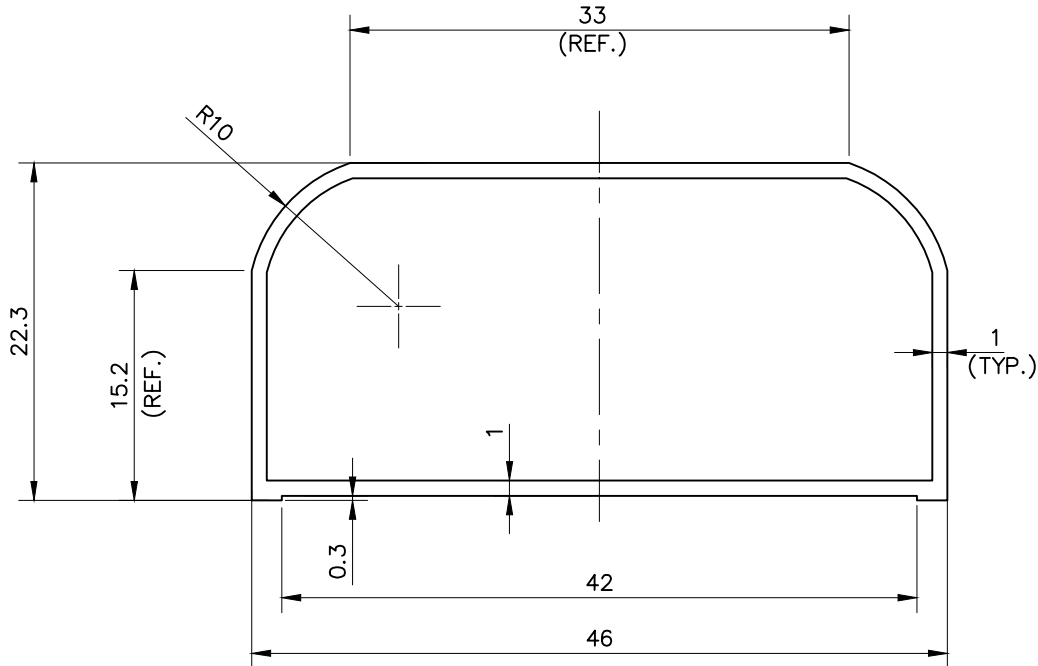

SCALE 1:1



- 1. STRAIGHTNESS= 1.7mm/M
- 2. TWIST= 1.7mm/M
- 3. ANGULARITY=  $\pm 2^\circ$
- 4. FLATNESS= 0.007xWIDTH

UNCONTROLLED COPY

1) THE WELDING LINE IN THE EXPOSED SURFACE OF PROFILE IS UNAVOIDABLE. 2) PLEASE SPECIFY IMPORTANT SIZES. 3) PLEASE SPECIFY IF THIS PROFILE MATCHES WITH OTHER PROFILES. 4) PLEASE SPECIFY EXPOSED SURFACE. OTHER WISE CONSIDERED AS NO EXPOSED SURFACE. 5) FINISH :-  MILL FINISH /  ANODIZING /  POWDER COATING

 SYMBOL OF QUALITY AN ISO 9001 COMPANY	<b>JINDAL ALUMINIUM LTD.</b> BHIWADI-301019 (INDIA)	NAME	DATE
		DRAWN	ASHUTOSH 03-05-2023
		CHECKED	
		APPROVED	
1. ALL DIMENSIONS ARE IN mm. 2. ROUND OFF ALL SHARP CORNERS WITH 0.40 mm. 3. TOLERANCES WILL BE AS PER BS:EN-755-9 , UNLESS OTHERWISE SPECIFIED		SCALE	1:1&2:1
		AREA mm <sup>2</sup>	126.51
PARTY'S NAME M/s. A.K. INTERNATIONAL ROORKEE U.K INDIA		PERIMETER mm.	130.09
		WEIGHT kg/m	0.342
PARTY'S DRAWING No. AS PER DRAWING -SECTION-2 (Q00581)		DRAWING No.	SECTION No.
ALLOY & TEMPER 6063-T6			
DESCRIPTION MISC. TUBE			