

VER	PLS	DESCRIPTION	CHD BY	DATE	APD BY	ECR
A	-	INITIAL RELEASE				1070
B	2	1. WAS 128 ±0.25 2. WAS 0.7 A B C	RPC	08MAR23	JV	1162
C	3	1. UPDATED MAIN PROFILE 2. WAS 105 3. UPDATED GD&T	RPC	18APR23	MJR	1196

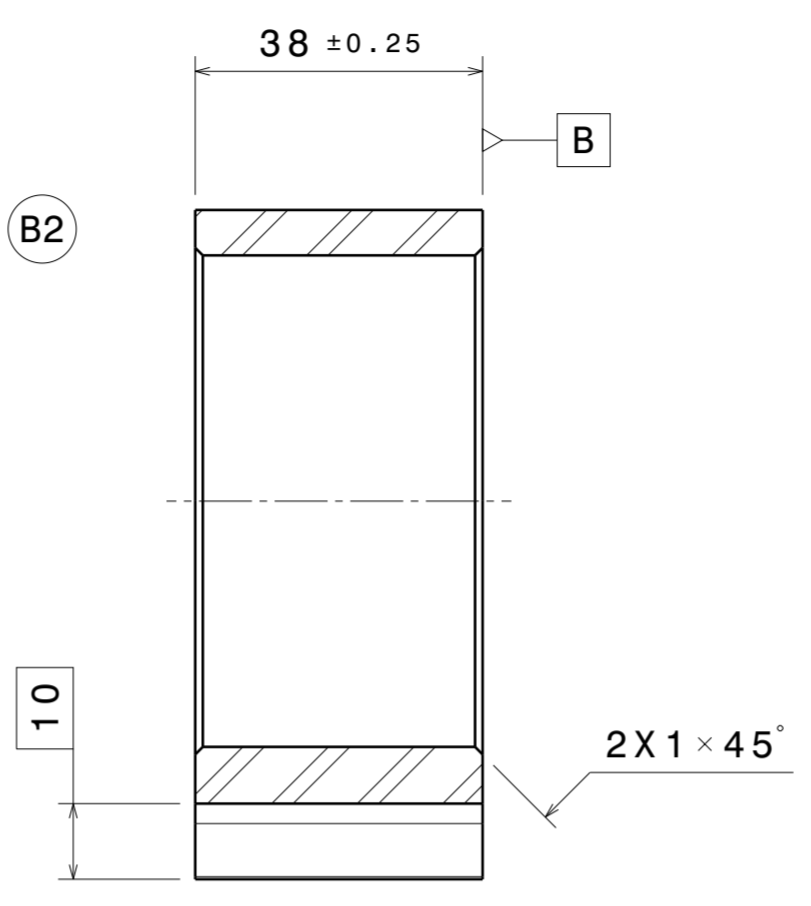

Section view A-A

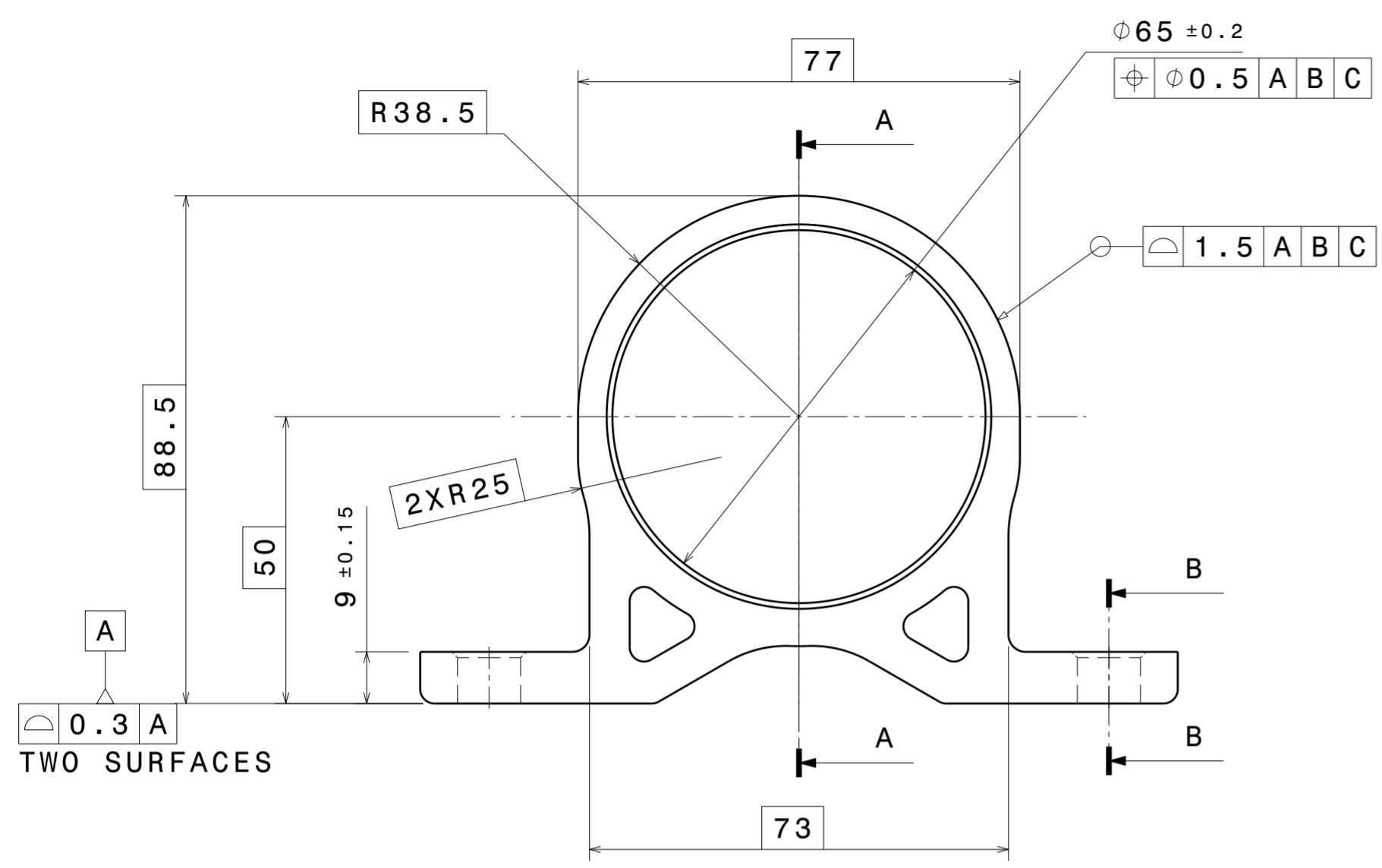
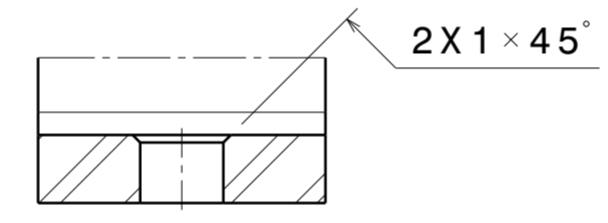
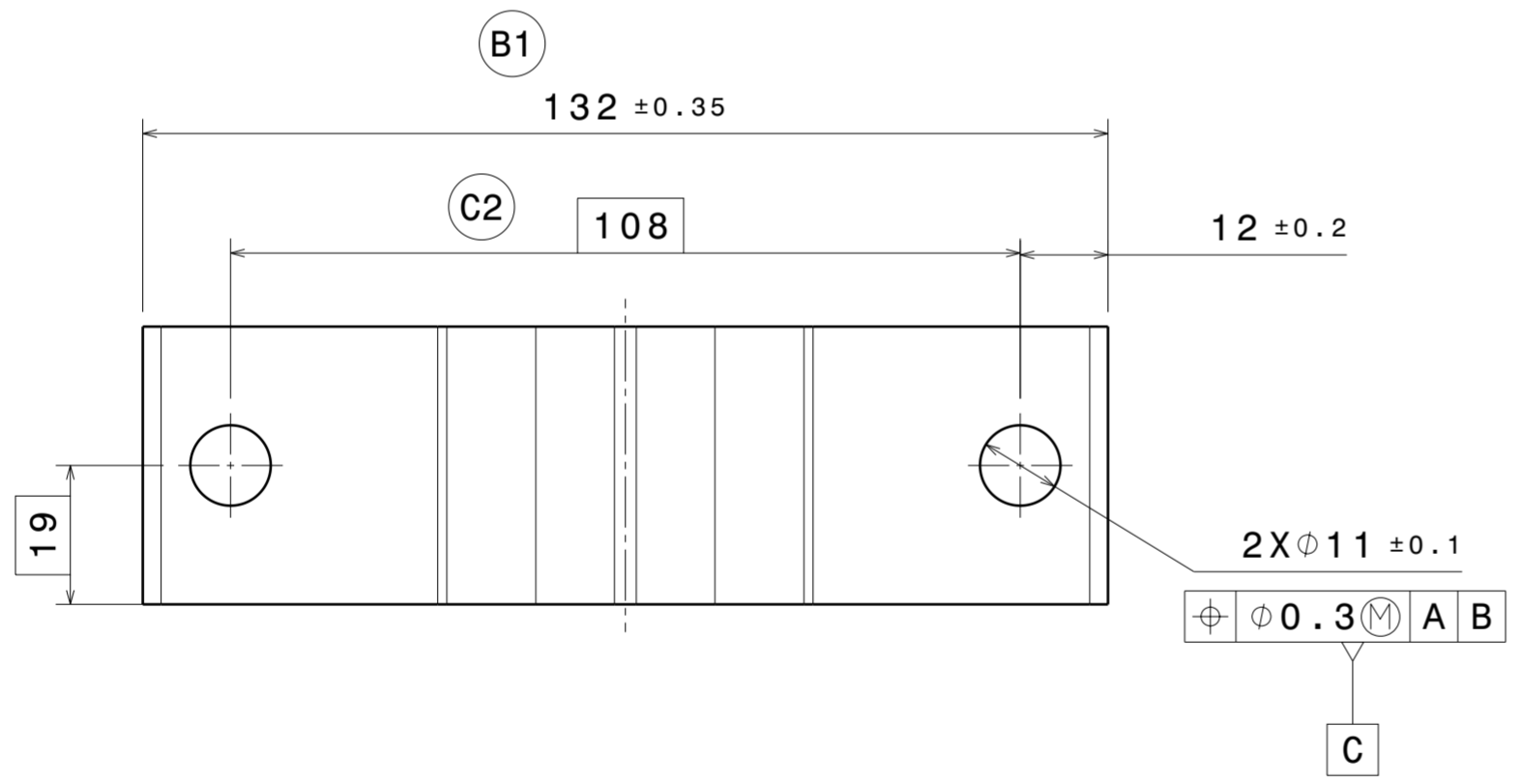

Section view B-B

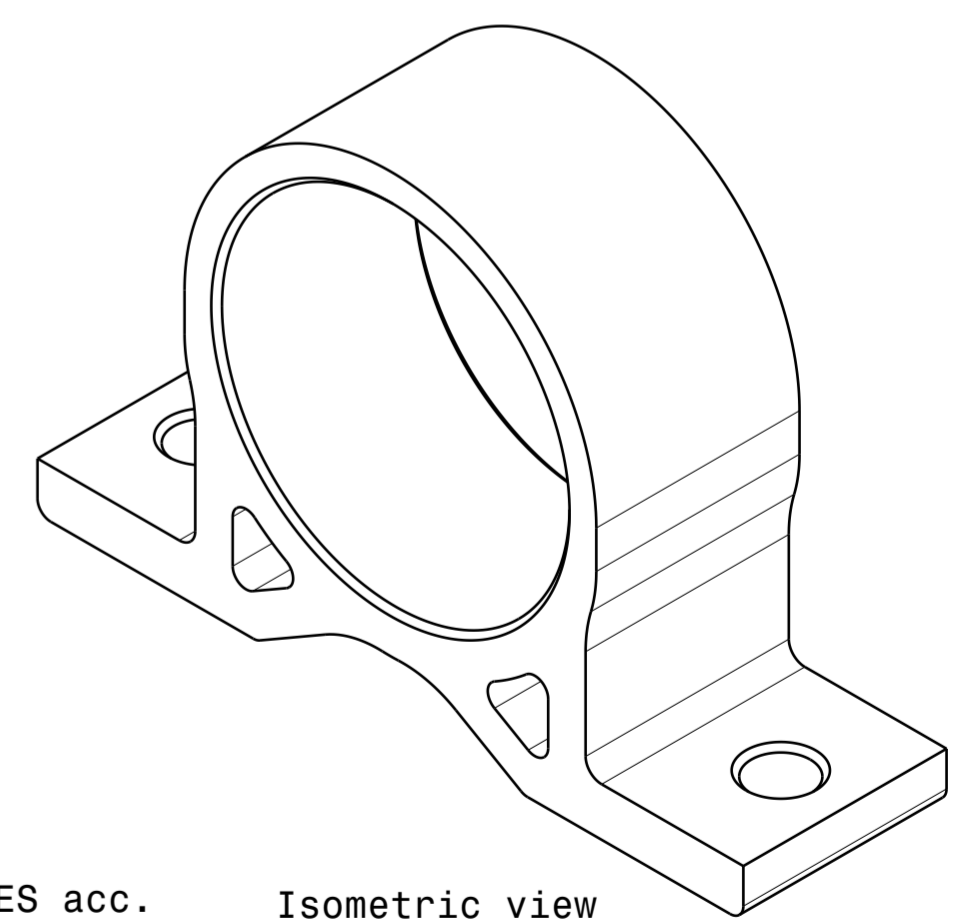

Isometric view
-0.2 EDGES acc. DIN ISO 13715

MATERIAL: ALUMINUM SAE 6082-T6 OR EQ.

DELIVERY CONDITION:
SURFACES TO BE FREE OF GRAPHITE,
SILICONE COMPOUNDS, MOLYBDENUM
DISULPHIDE, SULFUR AND DIRT

DRN. BY: R. CHURCH	01NOV22	PROPERTY OF ANP	
APD. BY: J. VANCE	01NOV22	THIS DRAWING IS THE SOLE PROPERTY OF ANP. IT CANNOT BE COPIED BY ANYONE WITHOUT WRITTEN PERMISSION OF ANP	
CAD SYSTEM: CATIA V5	PROTECTION MARK: ISO 16015	ANAND NVH PRODUCTS INC.	
TOLERANCED: ISO 2768-mk	ISO 8015	UNIT - MM	MODEL IS MASTER FOR ALL NON-DIMENSIONED FEATURES
ISO 3302-M3 (RUBBER)	DIN 16901 (PLASTIC)	SCALE - 1:1	SHEET - A2
MASS: 0.275kg	○ CALCULATED - ACTUAL	THIRD ANGLE PROJ	TITLE: HOUSING
CUST REFERENCE NO. XXXXX	PRODUCTION REFERENCE NO. XXXXX	PART NO.: U-P01683-D02	C