

BEFORE APPROVAL CHECK ALL DIMENSIONS PROPERLY

PROPOSED DRAWING
Q00615

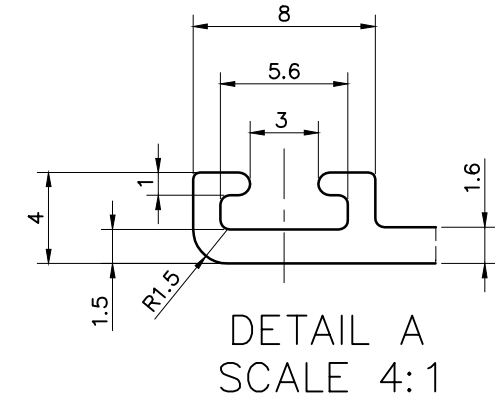
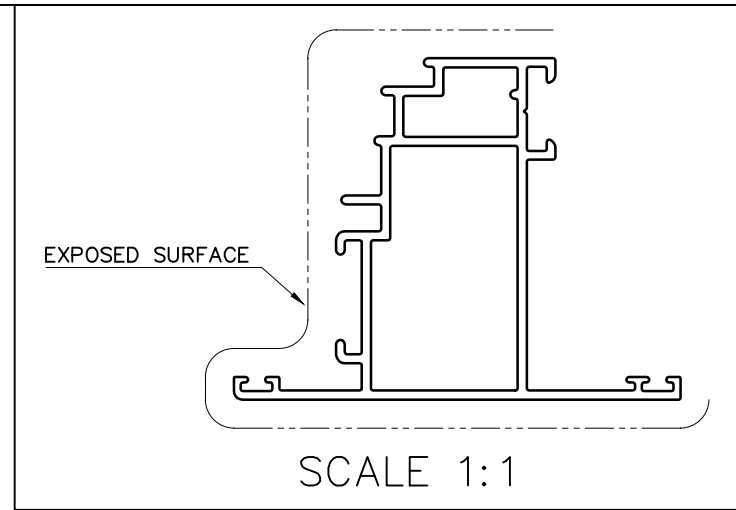
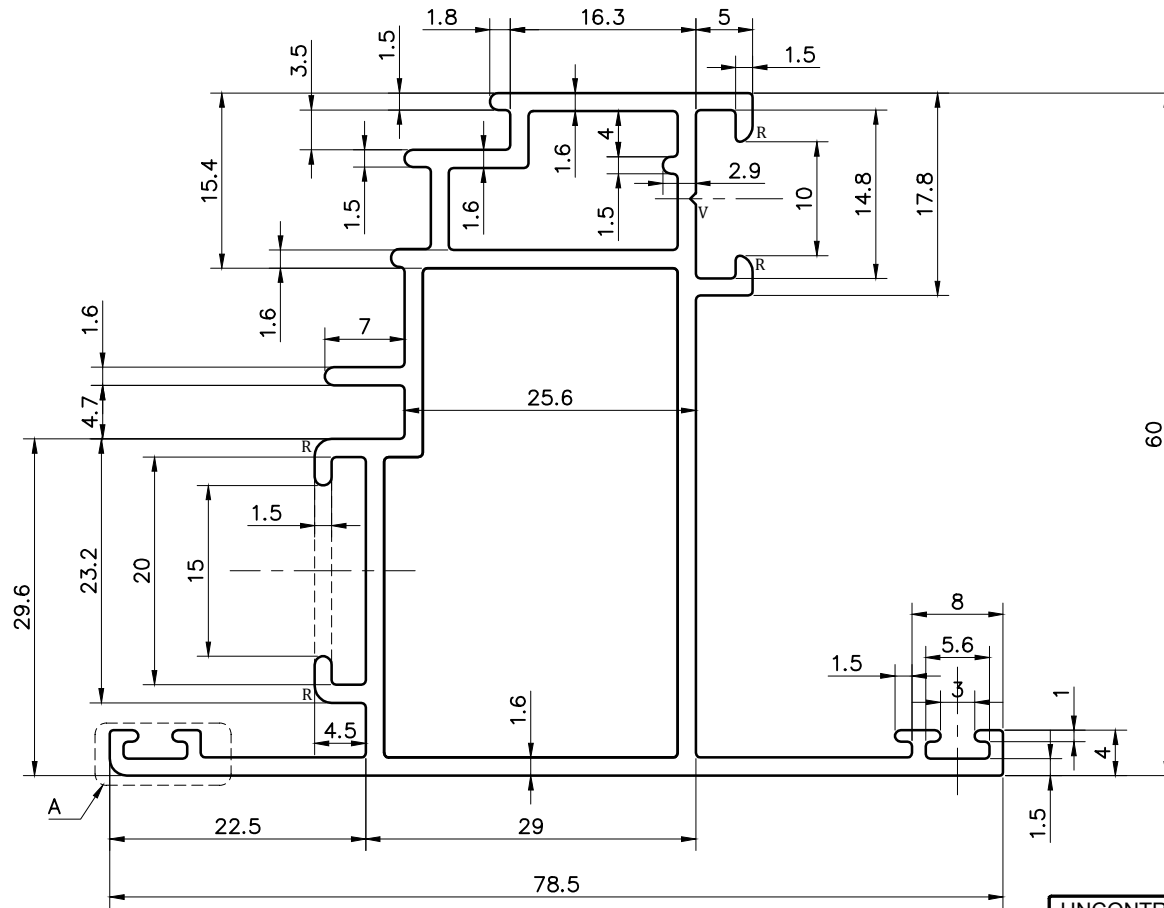

NOTE:-
R= 1.50 RADIUS (4 PLACES)
V= 0.5x90° V-GROOVE (1 PLACE)

UNCONTROLLED COPY

1) THE WELDING LINE IN THE EXPOSED SURFACE OF PROFILE IS UNAVOIDABLE. 2) PLEASE SPECIFY IMPORTANT SIZES. 3) PLEASE SPECIFY IF THIS PROFILE MATCHES WITH OTHER PROFILES. 4) PLEASE SPECIFY EXPOSED SURFACE. OTHERWISE CONSIDERED AS NO EXPOSED SURFACE. 5) FINISH :- MILL FINISH / ANODIZING / POWDER COATING

 SYMBOL OF QUALITY AN ISO 9001 COMPANY	JINDAL ALUMINIUM LTD. BHIWADI-301019 (INDIA)		NAME	DATE
			DRAWN	ASHUTOSH 24-04-2023
1. ALL DIMENSIONS ARE IN mm. 2. ROUND OFF ALL SHARP CORNERS WITH 0.40 mm. 3. TOLERANCES WILL BE AS PER BS:EN-755-9, UNLESS OTHERWISE SPECIFIED			CHECKED	
			APPROVED	
PARTY'S NAME M/s. MEHAR INDIA			SCALE	1:1&2:1
			AREA mm ²	464.98
PARTY'S DRAWING No. AS PER DRAWING-CKIN0569 (Q00615)			PERIMETER mm.	376.91
			WEIGHT kg/m	1.255
ALLOY & TEMPER 6063-T6			DRAWING No.	SECTION No.
			-	
DESCRIPTION WINDOW SECTION				