

P-JAL-B-203

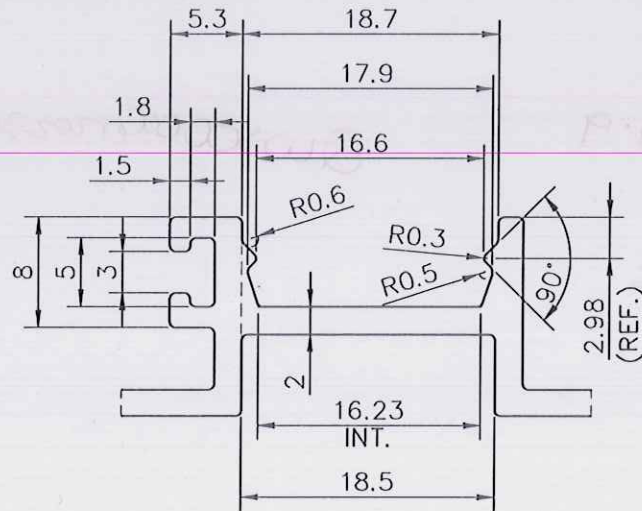

DETAIL A
SCALE 2:1

Q00681

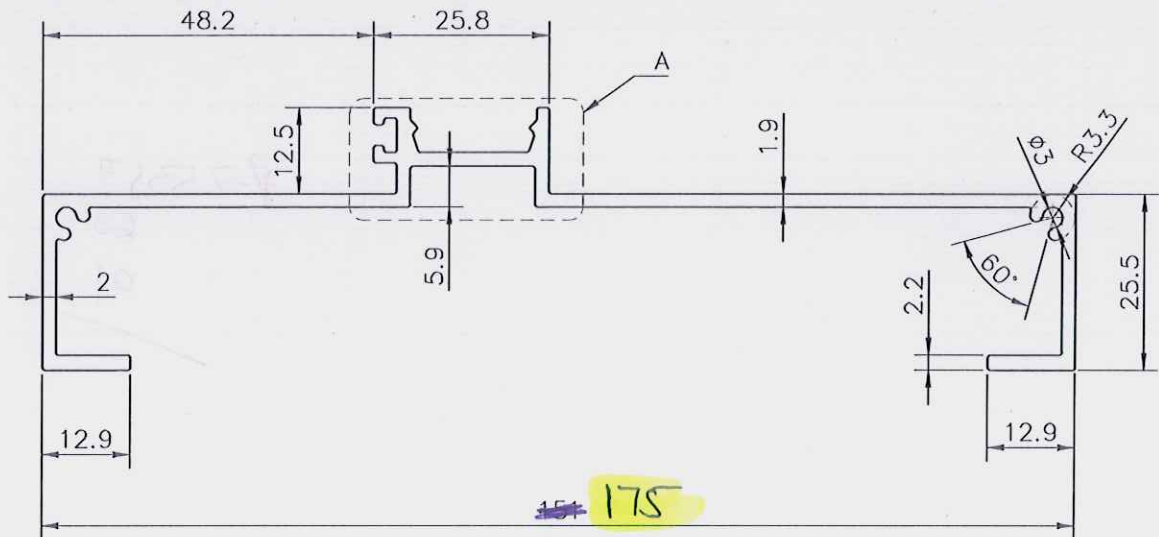

175

NOTE:-
MANY DIMENSIONS ARE NOT SPECIFIED IN YOUR DRAWING
PLEASE CHECK ALL DIMENSION CAREFULLY & CONFIRM

1. STRAIGHTNESS= 1.7mm/M
2. TWIST= 1.7mm/M
3. ANGULARITY= $\pm 2'$
4. FLATNESS= 0.007xWIDTH

Q00651

UNCONTROLLED COPY

1) THE WELDING LINE IN THE EXPOSED SURFACE OF PROFILE IS UNAVOIDABLE. 2) PLEASE SPECIFY IMPORTANT SIZES. 3) PLEASE SPECIFY IF THIS PROFILE MATCHES WITH OTHER PROFILES. 4) PLEASE SPECIFY EXPOSED SURFACE. OTHERWISE CONSIDERED AS NO EXPOSED SURFACE. 5) FINISH :- MILL FINISH / ANODIZING / POWDER COATING



SYMBOL OF QUALITY
AN ISO 9001 COMPANY

JINDAL ALUMINIUM LTD.
BHIWADI-301019 (INDIA)

	NAME	DATE
DRAWN	ASHUTOSH	19-05-2023
CHECKED		
APPROVED		

1. ALL DIMENSIONS ARE IN mm.
2. ROUND OFF ALL SHARP CORNERS WITH 0.40 mm.
3. TOLERANCES WILL BE AS PER BS:EN-755-9, UNLESS OTHERWISE SPECIFIED

SCALE	1:1
AREA mm ²	515.570
PERIMETER mm.	514.5
WEIGHT kg/m	1.392

PARTY'S NAME	VE-LUXE SOLUTIONS PRIVATE LIMITED, NOIDA
PARTY'S DRAWING No.	AS PER DRAWING
ALLOY & TEMPER	6063-T6
DESCRIPTION	CURTAIN-WALL SECTION

DRAWING No.	SECTION No.
P-JAL-B-203	