

ALT. NO.	ALT. DATE	ZONE	ALTERATIONS	AUTHORITY
0	09/02/2012	D7	1. NOTE NO.3 DELETED.	MD46141 DATED 19.01.2012

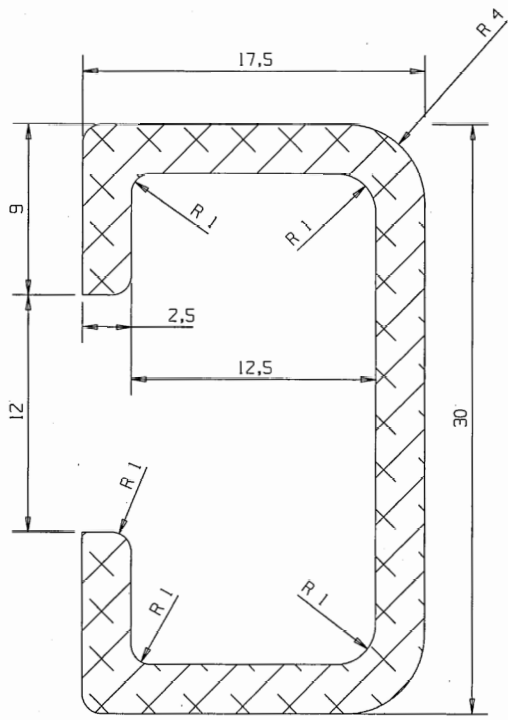

NOTE:-

- CROSS-SECTIONAL AREA=176.0 mm²
- WEIGHT/UNIT LENGTH =0.477 Kg/m.
- ~~MATERIAL SHOULD BE PURCHASED IN LENGTHS OF 5000mm.~~
- THIS COMPONENT SHALL BE MANUFACTURED ONLY BY EXTRUSION PROCESS.
- DIMENSIONAL TOLERANCES ON CROSS SECTION, TWIST, STRAIGHTNESS, LENGTH ETC SHALL CONFORM TO IS: 3965-81, IS: 2673-79, IS: 6477-83 UNLESS OTHERWISE SPECIFIED.
- COMPONENT SHALL BE DULL ANODISED TO IS: 1868-82, TAB-1 GR. AC 10.
- THIS ITEM IS TO BE USED INSIDE THE COACH. IT SHOULD HAVE AN ELEGANT FINISH AND THERE SHALL BE NO PITTING /CORROSION MARKS ON THE SURFA

THIS DRAWING IS THE INTELLECTUAL PROPERTY OF RAIL COACH FACTORY, KAPURTHALA. ALL RIGHTS ARE RESERVED. NO PART OF THIS DRAWING OR ANY COMPONENTS, SOLD OR TRANSFERRED WITHOUT PERMISSION FROM CHIEF DESIGN ENGINEER, RAIL COACH FACTORY, KAPURTHALA.

15 FEB 2012

NIL	ALUMINIUM PROFILE	NIL	NIL	IS:733-83 GR.63400 WP	NIL	
WELD LENGTH	ITEM	DESCRIPTION & DIMENSIONS	SPASSLY	DETAIL DRG	MATL. & SPEC.	REMARKS
NIL	M	GROUP	CEILING & MOULDINGS	SUPERSEDES:	LW44173 ALT	NIL
WEIGHT	FILE	lw44173a.prt (3D)				
NIL	KG	ALUMINIUM PROFILE			SCALE	SSE/REC
S.AREA				1:1	CHD	DUGL
NIL	M ²				DRN	HARI
LENGTH /-0+0.1				REF.DRG.NO. NTL		
NIL	M	RAIL COACH FACTORY, KAPURTHALA			PL NO. NIL	
WIDTH /-THICK				DRG.NO. LW44173		
NIL	M	रेल कोच फैक्टरी कपूरथला			N.R	
HEIGHT				ALT. 0 SIZE A3 SHEET 1/1		
NIL	M	19/2 ADE/SME			DY.CME	

G
 DETAIL DRGS STARTING WITH "LI" ARE INTERNAL REFERENCE LISTS ONLY AND ARE NOT FOR ISSUE.
 THIS IS A COMPUTER GENERATED DRAWING. ANY MANUAL ALTERATION SHALL AUTOMATICALLY RENDER IT INVALID.
 FOR UNTOLERANCED DIMENSIONS REFER MDG0008 | DATE OF FIRST ISSUE 25/09/2001 | CGM BY *slavsh*