

ENQUIRY NO./DATE : C-23-17 / 20-04-2017  
 CUSTOMER/CUSTOMER REF.NO: SILVER LINE / CAD DRG.  
 END USE:-

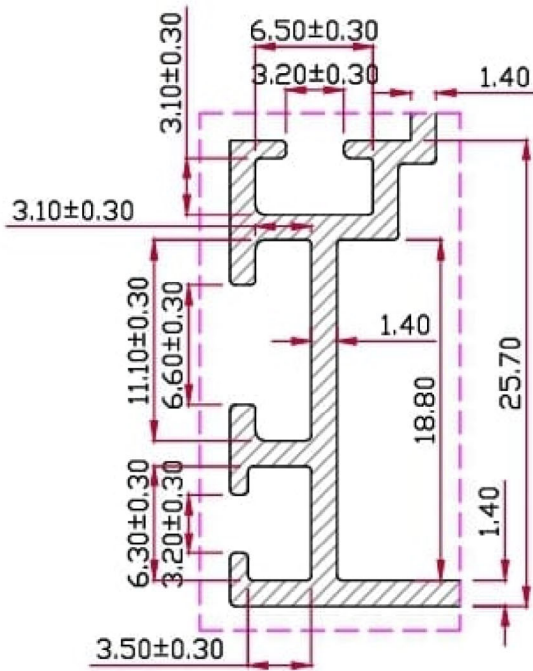

DETAIL VIEW OF A

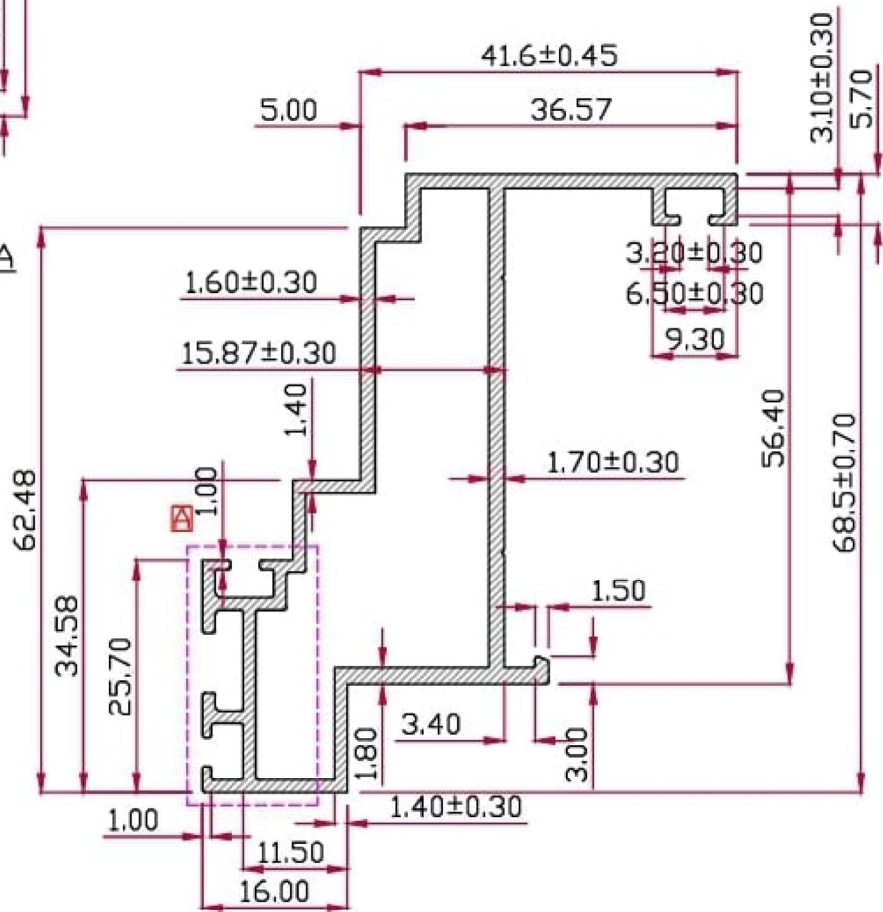

S-9053  
 1.082 kg/mtr

- (1) ALL DIMENSIONS ARE IN MM.
- (2) ALL SHARP CORNERS REMOVED WITH 0.30 MM RADIUS
- (3) UNLESS OTHERWISE NOT SPECIFIED TOLERANCE IS:- IS:2673,IS:6477,IS:3965  
 NO WEIGHT RANGE WILL BE CONSIDERED. MATERIAL WILL BE SUPPLIED AS PER DIMENSION ONLY.

(4) PLEASE MARK EXPOSED AREA DURING APPROVAL.

(5) END SURFACE FINISH TO BE DONE AT CUSTOMER END: ANODIZING/POWDER COATING

REVISIONS:- -