

Q00168

TECHNICAL REQUIREMENTS :

- 1) UNSPEC. THICKNESS :  $\pm 0.15$
- 2) EXE STD : GB5237.1-2008 HIGH PRECISION
- 3) "( ) " IS THE REFERENCE SIZE, WITHOUT ANY REQUEST
- 4) SURFACE FINISH FREE FROM SCRATCHES / MATT FINISH AS PER WEL SAMPLE WITH POLYTHIN

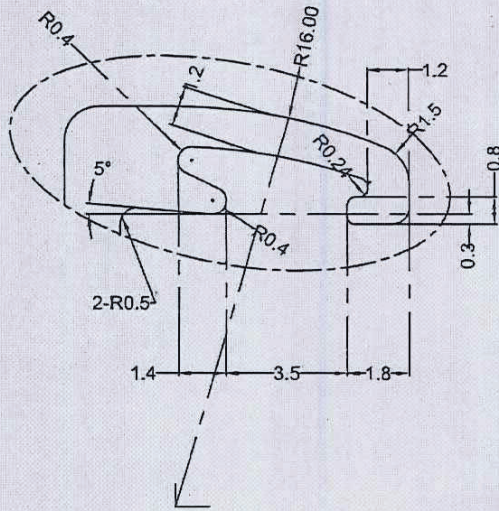

DETAILS A  
SCALE 1 : 2.5

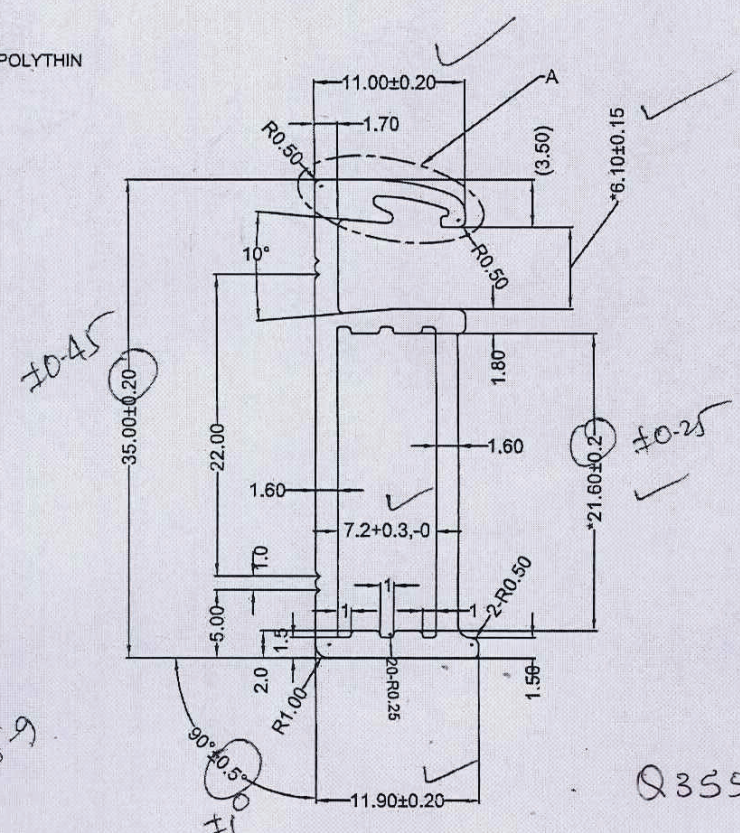

6005 alloy  
ok

Note :-

1. Unspec. wall thickness T \_\_\_\_\_ MM
2. Unspec. corners round to R 0.25 MM
3. \_\_\_\_\_ is exposed surface.
4. Perimeter \_\_\_\_\_ MM
5. Section area 142.76 MM<sup>2</sup>
6. Line density 0.387 kg/m
7. Circumcircle \_\_\_\_\_ MM

GB 5237. 1-2008 (High Precision)

Size	Tolerance
≤ 3	±0.13
> 3-10	±0.15
> 10-15	±0.17
> 15-30	±0.21
> 30-45	±0.26
> 45-60	±0.31
> 60-100	±0.52

THIRD ANGLE PROJECTION



USE 3D MODEL FOR  
NON-SPECIFIED GEOMETRY

THE INFORMATION CONTAINED IN THIS  
DRAWING IS THE SOLE PROPERTY OF  
WAAREE ENERGIES LIMITED. ANY  
REPRODUCTION IN PART OR AS A WHOLE  
WITHOUT THE WRITTEN PERMISSION OF  
WAAREE ENERGIES IS PROHIBITED.

SIGNATURE

DATE

DRAWN	04/06/2022
CHK	04/06/2022
APR	04/06/2022

**WAAREE®**

One with the Sun

WAAREE ENERGIES LIMITED

ALL DIMENSION IN MM  
UNLESS OTHERWISE SPECIFIED

MATERIAL :-  
**AL-ALLOY-6005-T6**

DESCRIPTION	SIZE/ DWG NO	REV
		007
SCALE	SHEET 2 OF 4	