

PROPOSED DRAWING

Q00189

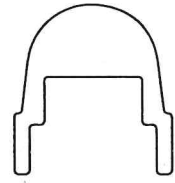

SCALE 1:1

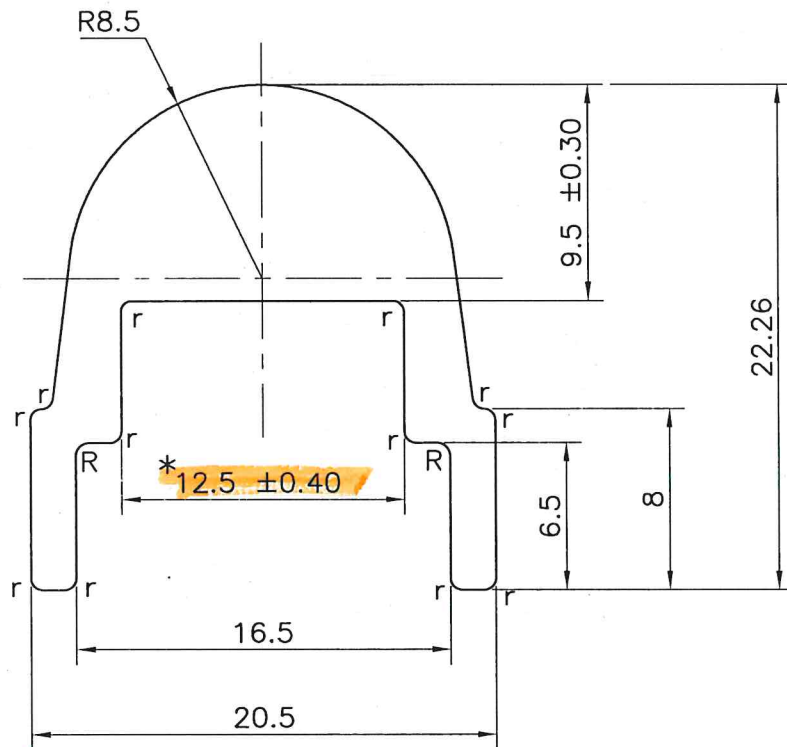

NOTE:-

r = 0.50R
R = 0.60R

NOTE:-

- ① HARDNESS:- 85-90 HB
- ② * DIM. 12.5 ± 0.40mm



SYMBOL OF QUALITY
AN ISO 9001 COMPANY

JINDAL ALUMINIUM LTD.
BHIWADI-301019 (INDIA)

- 1. ALL DIMENSIONS ARE IN mm.
- 2. ROUND OFF ALL SHARP CORNERS WITH 0.40 mm.
- 3. TOLERANCES WILL BE AS PER BS:EN-755-9 , UNLESS OTHERWISE SPECIFIED

		NAME	DATE
PARTY'S NAME		ASHUTOSH	13-10-2022
PARTY'S DRAWING No.		<i>Junil</i>	14-10-22
ALLOY & TEMPER		<i>Jtkan</i>	14.10.22
DESCRIPTION			
		SCALE	1:1&3:1
		AREA mm ²	194.94
		PERIMETER mm.	99.25
		WEIGHT kg/m	0.526
		DRAWING No.	SECTION No.