

PROPOSED DRAWING

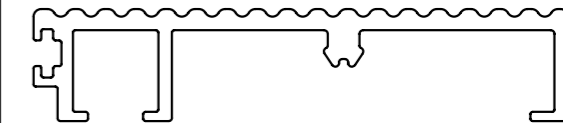

SCALE 1:1

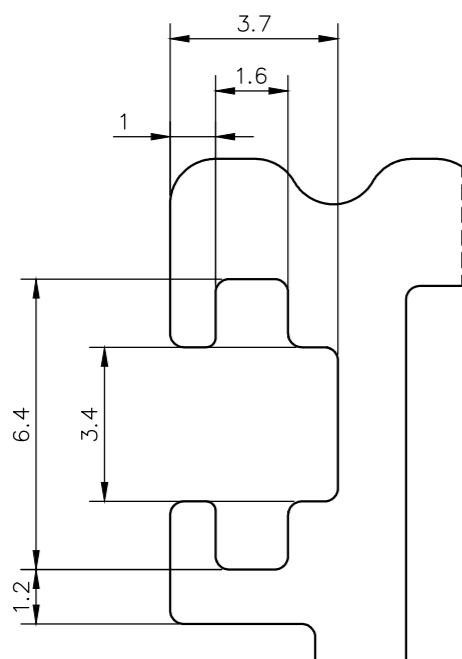
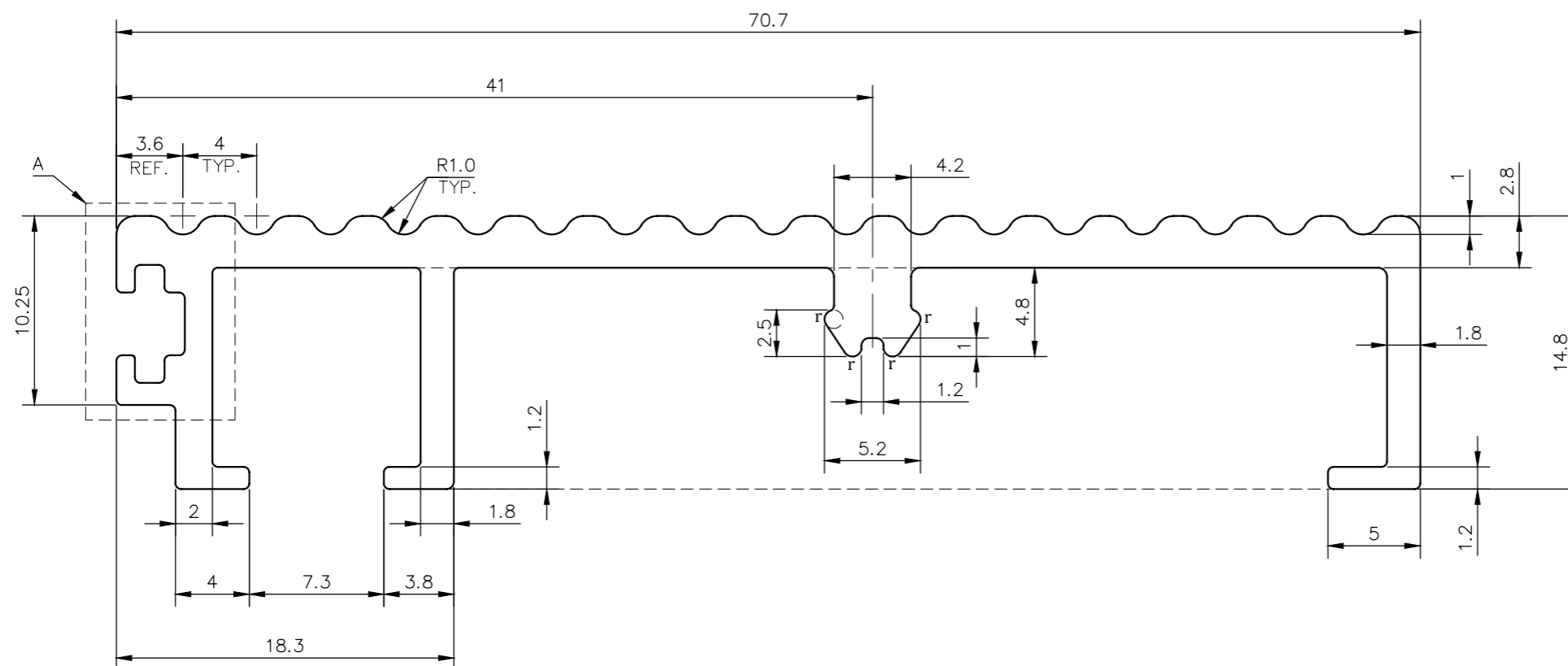

DETAIL A
SCALE 6:1

NOTE:-
r= 0.50 RADIUS (4 PLACES)

1. STRAIGHTNESS= 1.7mm/M
2. TWIST= 1.7mm/M
3. ANGULARITY= ±2°
4. FLATNESS= 0.007xWIDTH

UNCONTROLLED COPY

(Q00709)

- 1) THE WELDING LINE IN THE EXPOSED SURFACE OF PROFILE IS UNAVOIDABLE.
- 2) PLEASE SPECIFY IMPORTANT SIZES.
- 3) PLEASE SPECIFY IF THIS PROFILE MATCHES WITH OTHER PROFILES.
- 4) PLEASE SPECIFY EXPOSED SURFACE. OTHERWISE CONSIDERED AS NO EXPOSED SURFACE.
- 5) FINISH :- MILL FINISH / ANODIZING / POWDER COATING

 SYMBOL OF QUALITY AN ISO 9001 COMPANY	JINDAL ALUMINIUM LTD. BHIWADI-301019 (INDIA)	NAME	DATE
		DRAWN	ASHUTOSH 06-06-2023
		CHECKED	
		APPROVED	
1. ALL DIMENSIONS ARE IN mm. 2. ROUND OFF ALL SHARP CORNERS WITH 0.40 mm. 3. TOLERANCES WILL BE AS PER BS:EN-755-9, UNLESS OTHERWISE SPECIFIED		SCALE	3:1
		AREA mm ²	269.55
		PERIMETER mm.	264.43
		WEIGHT kg/m	0.728
PARTY'S NAME	PRANAV DOORS & WINDOWS PVT. LTD., MOHALI	DRAWING No.	SECTION No.
PARTY'S DRAWING No.	AS PER AUTOCAD-PF0117		
ALLOY & TEMPER	6063-T6		
DESCRIPTION	ARCHITECTURAL MISC. SECTION		