

REMOVE ALL SHARP CORNERS/EDGES

CAD DRAWING DO NOT MODIFY

DO NOT SCALE DRAWING

UNCONTROLLED COPY
NOT FOR PRODUCTION
UNLESS OVERSTAMPED
"CONTROLLED"
IN RED INK

| BY | DATE | ALTERATIONS | ISSUE |
|-----|------------|--|-------|
| KDE | 30/06/2014 | PRODUCTION RELEASE PR14-043. Note 3 and rad details added | A |
| PH | 11/4/2014 | FOR COSTING PURPOSES ONLY | 1 |
| - | - | - | - |
| - | - | - | - |

NOTES

1. CSA = 65.6mm²
2. MATERIAL: ALUMINIUM
ALLOY 6063-T6 TO BS EN 755
3. TOLERANCES TO BS EN 755-9
4. A DENOTES R0.5 RAD
5. B DENOTES R1.0 RAD
6. ALL UNSPECIFIED RADS R0.5
7. VISIBLE SURFACES DENOTED BY -----

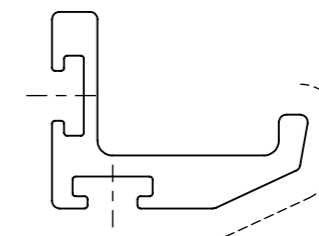
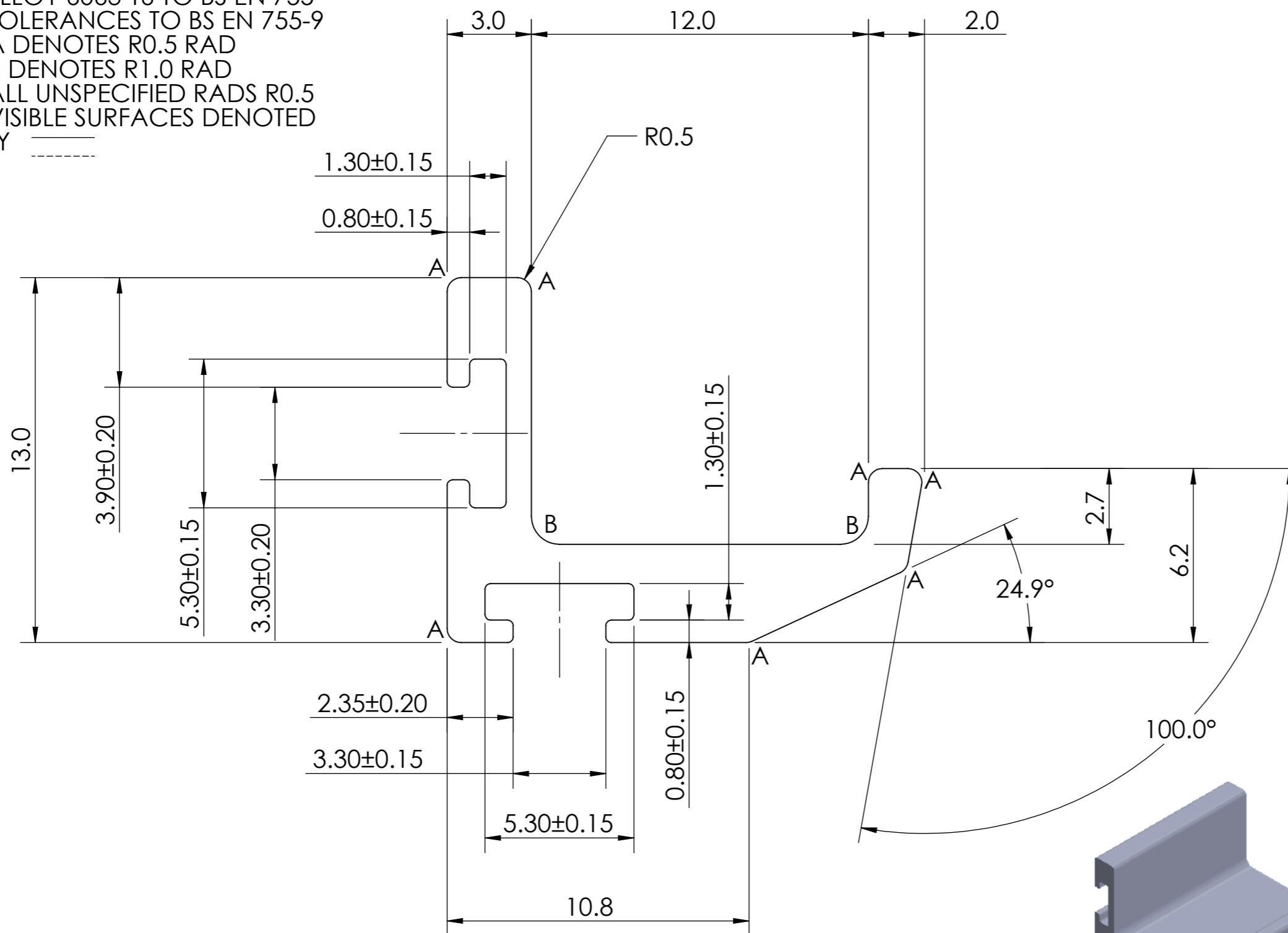

SCALE 2:1

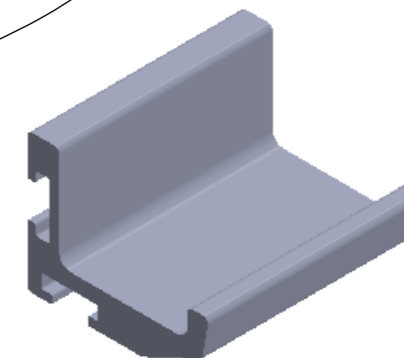

| | |
|----------|---------------|
| DESIGNER | PH 05/06/2014 |
|----------|---------------|

| | |
|---------------------------------------|-------------|
| TOLERANCES UNLESS OTHERWISE SPECIFIED | |
| X | ± |
| X.X | ± |
| X.XX | ± SEE NOTES |
| HOLE CRS | ± |
| ANGULAR | ± 0.5° |

| | |
|----------|-----------|
| MATERIAL | SEE NOTES |
|----------|-----------|

| | |
|--------|-------------|
| FINISH | SELF COLOUR |
|--------|-------------|

| | |
|--------|--------------------|
| WEIGHT | CE No. CE13-344 |
|--------|--------------------|



| | |
|-------|---------------------|
| TITLE | BOTTOM SEAL CARRIER |
|-------|---------------------|

| | | |
|---------|----------|---------------|
| PART No | 29/62669 | SHT 1 OF 1 |
| | | ISSUE A |

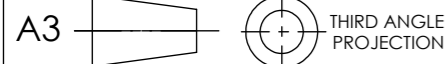

DIMENSIONS ARE IN MILLIMETRES UNLESS OTHERWISE STATED

METRIC SCREW THREADS SHALL CONFORM TO THE LIMITS AND TOLERANCES SPECIFIED IN THE CURRENT BS3643 PT2 CLASS 6g EXTERNAL OR 6H INTERNAL

© WIDNEY MANUFACTURING LTD THIS DOCUMENT IS CONFIDENTIAL AND THE DOCUMENT AND THE COPYRIGHT THEREIN ARE THE PROPERTY OF WIDNEY MANUFACTURING LTD. THE DOCUMENT AND ANY INFORMATION THEREIN MAY NOT BE USED COPIED OR DISCLOSED TO ANY THIRD PARTY WITHOUT THE PRIOR WRITTEN AUTHORISATION OF WIDNEY MANUFACTURING LTD