

BEFORE APPROVAL CHECK ALL DIMENSIONS PROPERLY

PROPOSED DRAWING

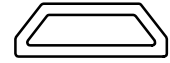

SCALE 1:1

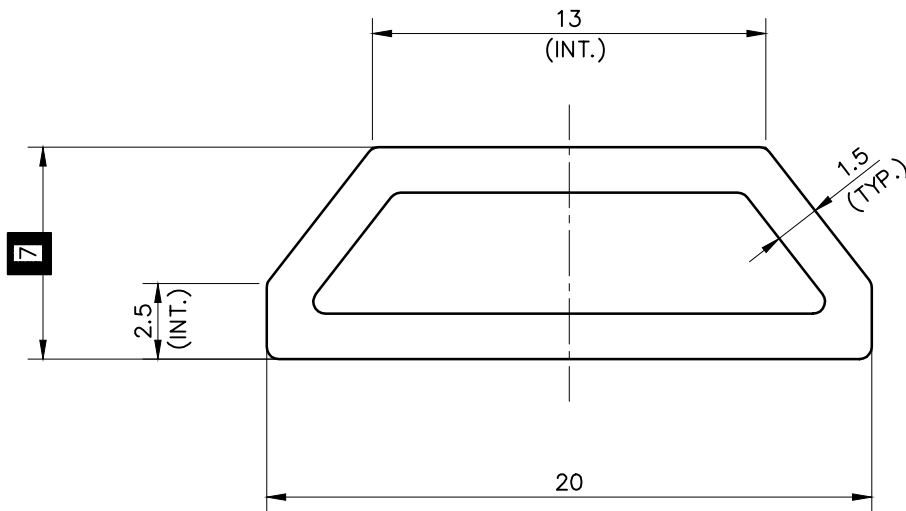

- 1. STRAIGHTNESS= 1.7mm/M
- 2. TWIST= 1.7mm/M
- 3. ANGULARITY= $\pm 2^\circ$
- 4. FLATNESS= 0.007xWIDTH

UNCONTROLLED COPY

1) THE WELDING LINE IN THE EXPOSED SURFACE OF PROFILE IS UNAVOIDABLE. 2) PLEASE SPECIFY IMPORTANT SIZES. 3) PLEASE SPECIFY IF THIS PROFILE MATCHES WITH OTHER PROFILES. 4) PLEASE SPECIFY EXPOSED SURFACE. OTHERWISE CONSIDERED AS NO EXPOSED SURFACE. 5) FINISH :- MILL FINISH / ANODIZING / POWDER COATING



SYMBOL OF QUALITY
AN ISO 9001 COMPANY

JINDAL ALUMINIUM LTD.
BHIWADI-301019 (INDIA)

	NAME	DATE
DRAWN	ASHUTOSH	15-04-2023
CHECKED		
APPROVED		
SCALE		1:1&4:1
AREA mm ²		65.90
PERIMETER mm.		48.98
WEIGHT kg/m		0.178
DRAWING No.		SECTION No.

- 1. ALL DIMENSIONS ARE IN mm.
- 2. ROUND OFF ALL SHARP CORNERS WITH 0.40 mm.
- 3. TOLERANCES WILL BE AS PER BS:EN-755-9 , UNLESS OTHERWISE SPECIFIED

PARTY'S NAME	M/s. TUTEJA WINDOW SOLUTION
PARTY'S DRAWING No.	AS PER SAMPLE
ALLOY & TEMPER	6063-T6
DESCRIPTION	MISC. TUBE