

Detail A
Scale 2:1

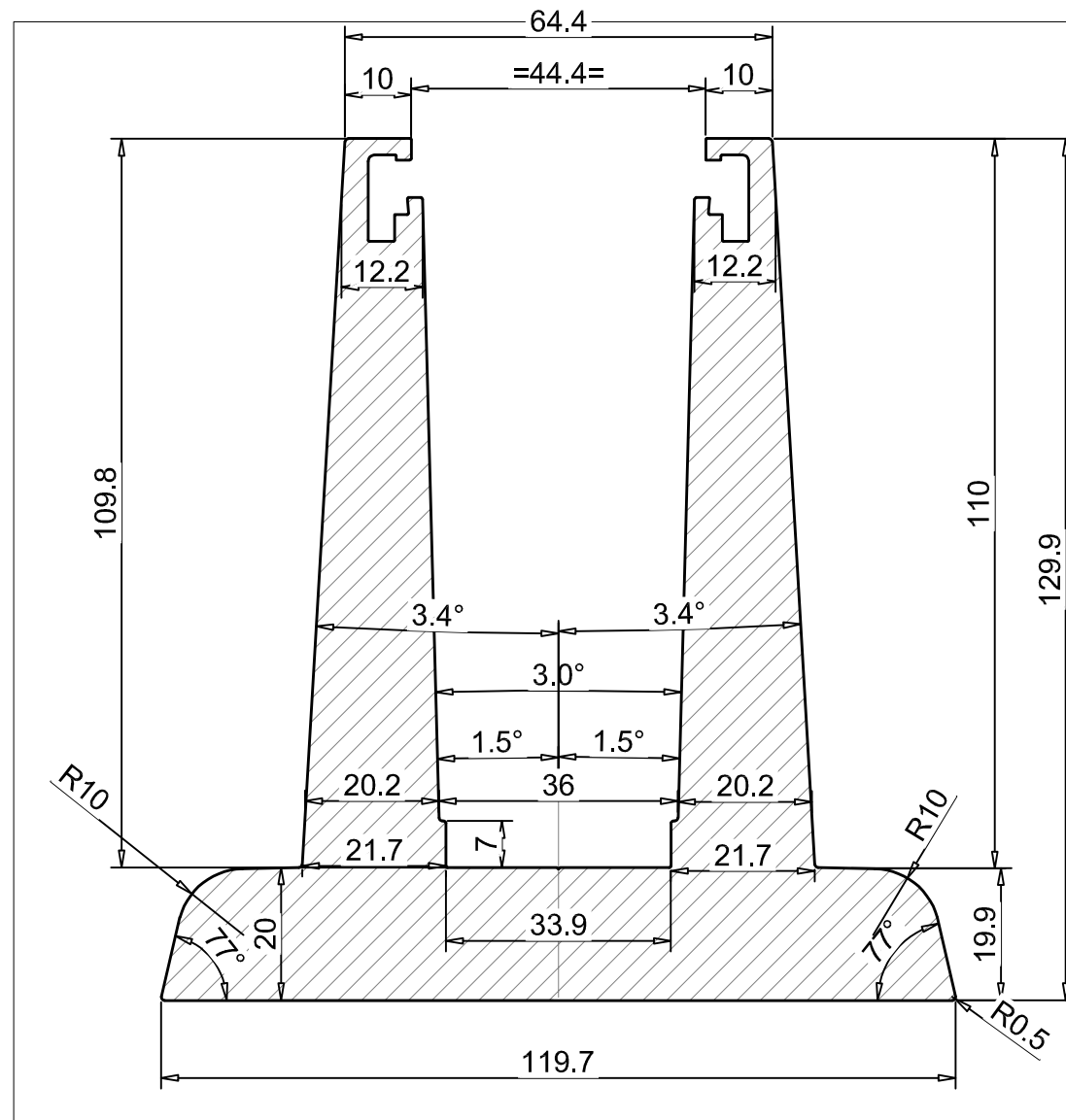

Scale 1:1

Weight = = 15.368 Kg / Mtr

Special Feature:-

1. Anodizable.
 2. No Machining
 3. To Bend- No
 4. Alloy & Temper -T6063
- Cut Length :- To be decided

Material.-	Al.	Qty-	AL-Extrusion 130x120			
Customer			Project			
 GSC Alusystems Private Ltd Plot 41, Sector Ecotech-1, Extension-1, Greater Noida, Gautam Buddha Nagar UP India Pin 201310			Print:	Drg No: Mxxxx		
			Drawn By AKS	Date 27/04/2024	Version RevB4	Scale 1:1
			File: \\ax2\AX\Alusystems\ALUSYSTEM DEVELOPMENTS\GLASS LINE FITTING\GL130x120\Section 130x120 RevB4.dwg			