

Tolerance Instructions

- general tolerance on wall thickness = +/-0.1mm U.O.S
- general dimensional tolerance = +/-0.1mm U.O.S

C (20 : 1)

A (10 : 1)

B (10 : 1)

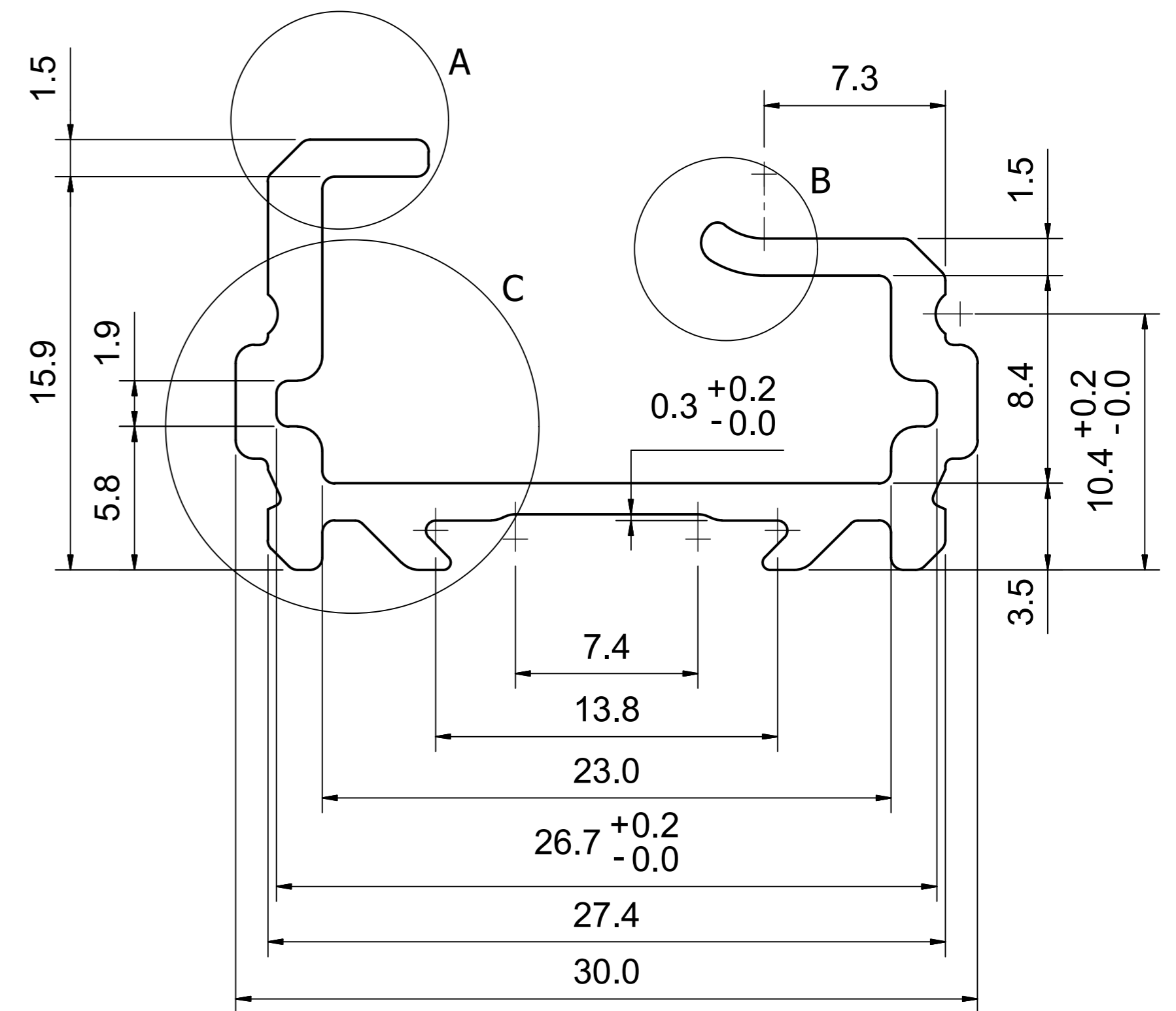
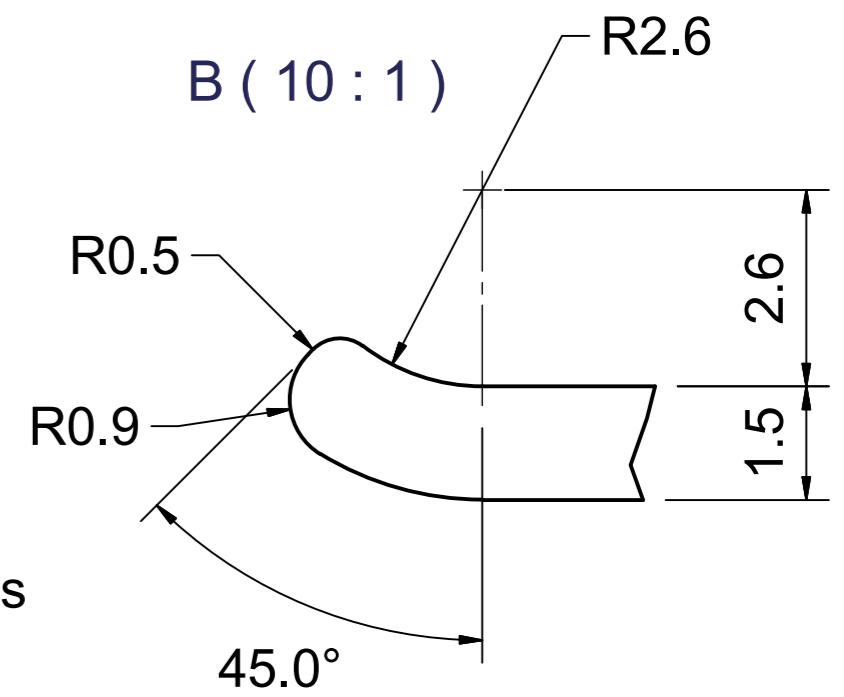
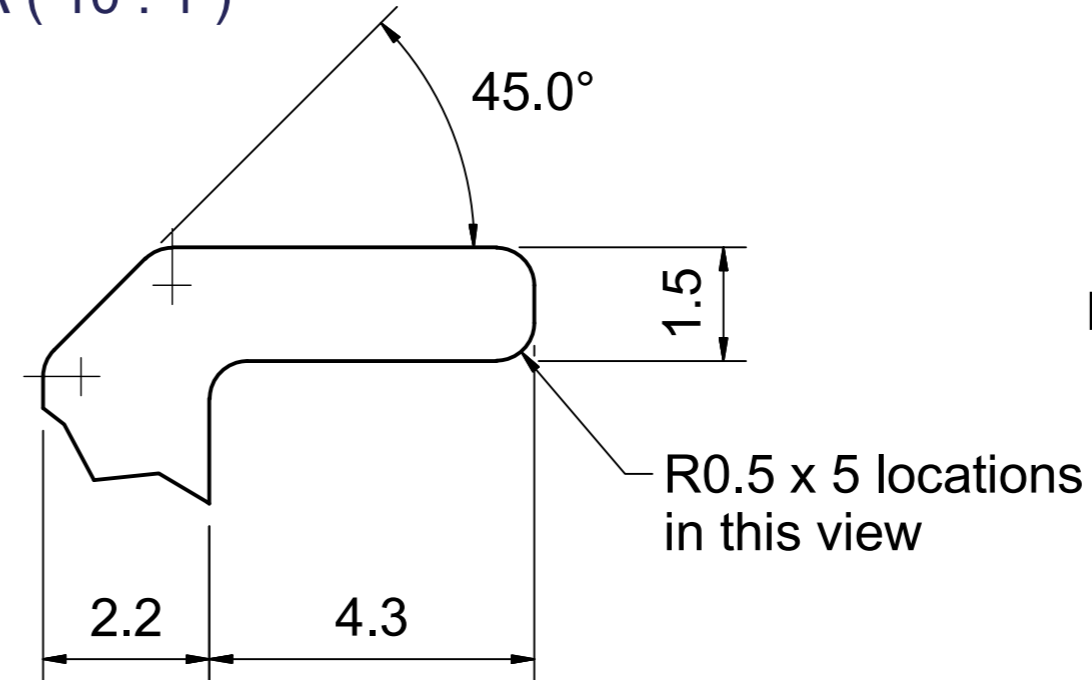
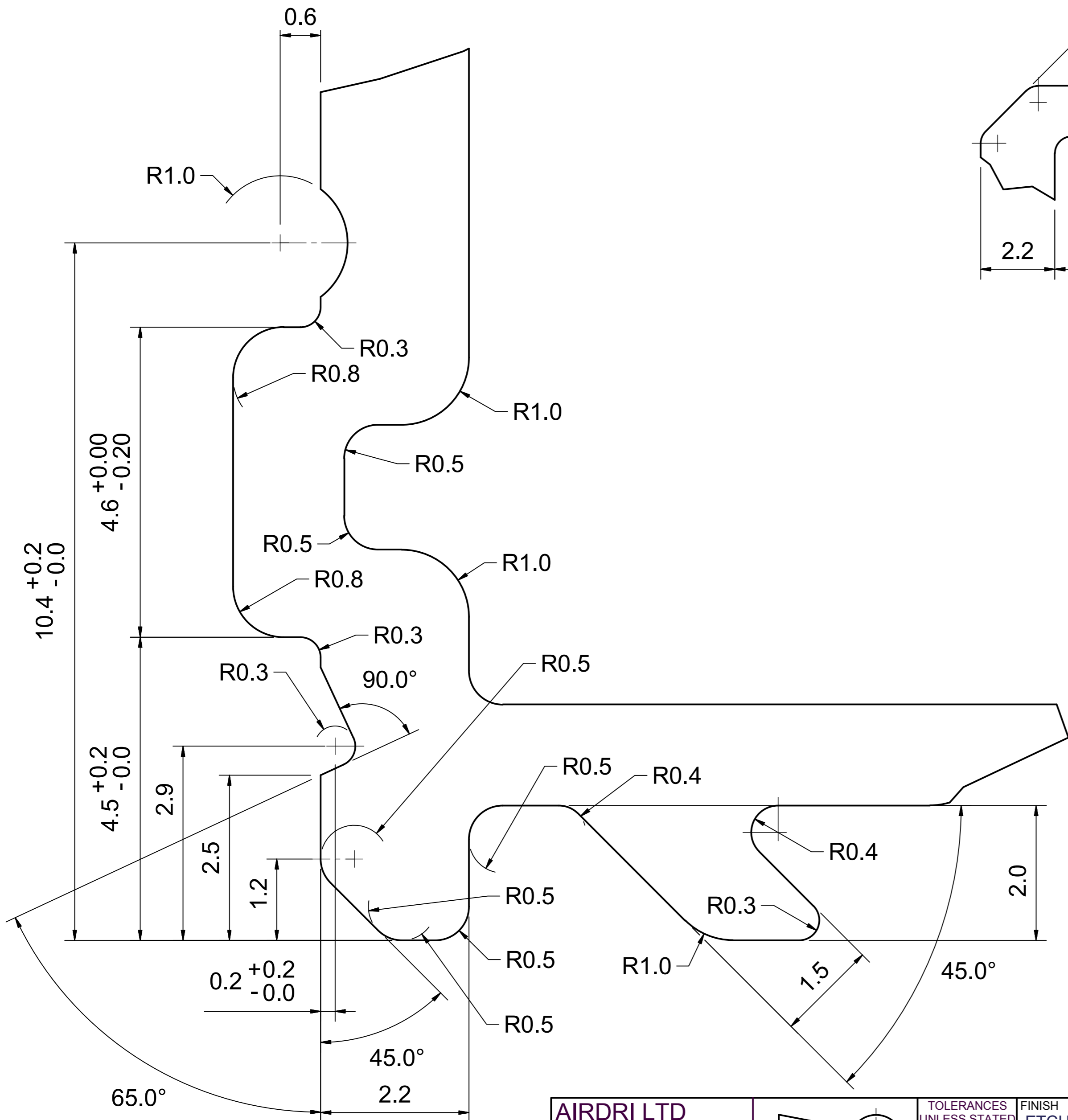

AIRDRI LTD
 Technology House, Oakfield Estate,
 Eynsham, OXFORD OX29 4AQ
 TEL +44(0)1865 882330
 FAX +44(0)1865 881647
 www.airdri.com
COPYRIGHT AIRDRI LTD 2002

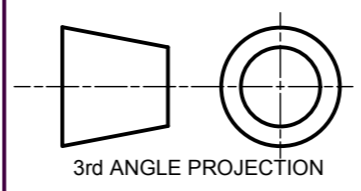

TOLERANCES
 UNLESS STATED
 LINEAR
 X ± 0.5mm
 X.X ± 0.3mm
 X.XX ± 0.1mm
 ANGULAR ± 15'

FINISH
 ETCH & ANODISED AA15
 (BS1615)
 BLACK

MATERIAL
 AL' ALLOY EXTRUSION
 6063 TO BS1474

ORIGINATOR RMP	TITLE EXTRUDED CHANNEL		
REVISED	SCALE	DRAWING NUMBER	PART NUMBER
	UNITS	APBC0842	APBC0842*
	mm	SHEET 1 OF 4	
STATUS	ISSUE	DATE	CHANGE
Released	3		APPROVED

DO NOT SCALE - REMOVE BURRS & SHARP EDGES
 LOCATION: C:\Users\Ron MacPhee\Desktop\Rubicon ID Projects\Airdri - 2016\ID1171 - Vision Detail Design\Up-dated CAD files\LS (New)\APBC0842.idw

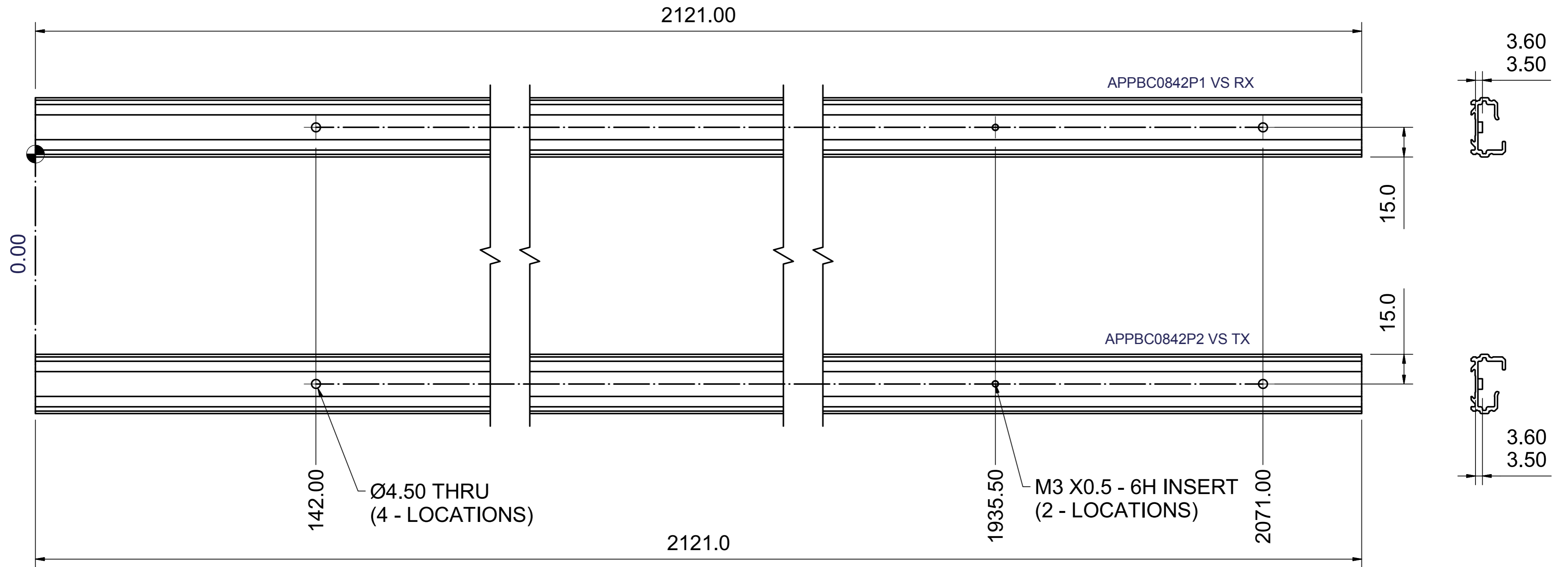

AIRDRI LTD
 Technology House, Oakfield Estate,
 Eynsham, OXFORD OX29 4AQ
 TEL +44(0)1865 882330
 FAX +44(0)1865 881647
 www.airdri.com
COPYRIGHT AIRDRI LTD 2002

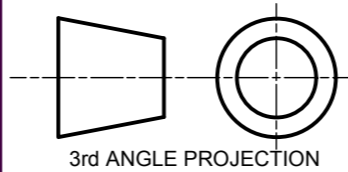

TOLERANCES
 UNLESS STATED
 LINEAR
 X ± 0.5mm
 X.X ± 0.3mm
 X.XX ± 0.1mm
 ANGULAR ± 15'

FINISH

DO NOT SCALE - REMOVE BURRS & SHARP EDGES

MATERIAL

ORIGINATOR
RMP

REVISED

STATUS

Released

TITLE **EXTRUDED CHANNEL**

SCALE
 DRAWING NUMBER
APBC0842

UNITS
 mm
 SHEET 2 OF 4

ISSUE
3

PART NUMBER
APBC0842*

APPROVED

LOCATION: C:\Users\Ron MacPhee\Desktop\Rubicon ID Projects\Airdri - 2016\ID1171 - Vision Detail Design\Up-dated CAD files\LS (New)\APBC0842.idw

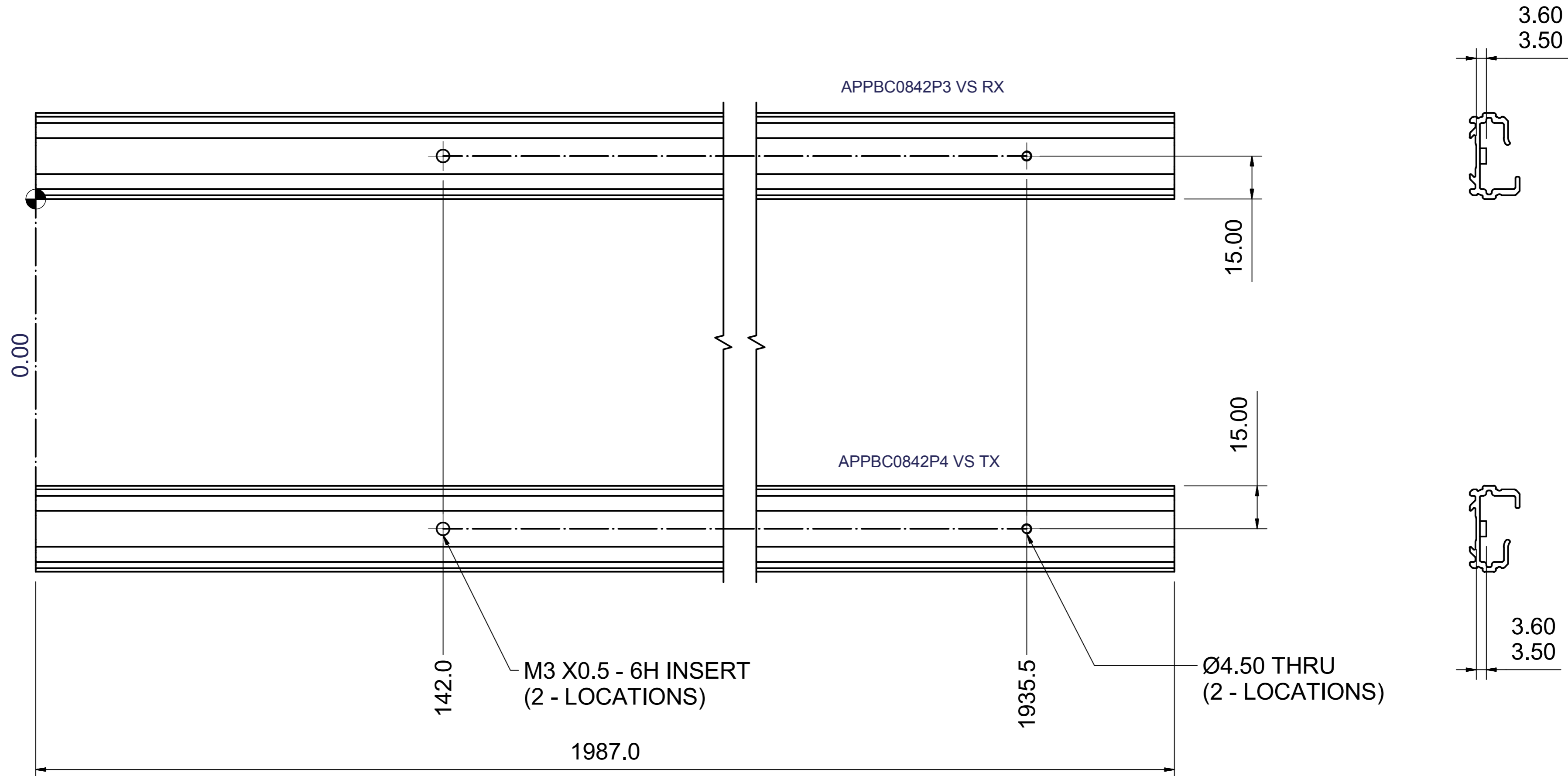

AIRDRI LTD
 Technology House, Oakfield Estate,
 Eynsham, OXFORD OX29 4AQ
 TEL +44(0)1865 882330
 FAX +44(0)1865 881647
 www.airdri.com
COPYRIGHT AIRDRI LTD 2002

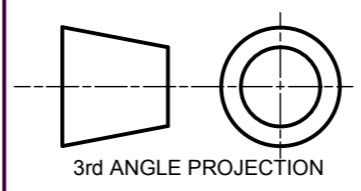

TOLERANCES
 UNLESS STATED
 LINEAR
 X ± 0.5mm
 X.X ± 0.3mm
 X.XX ± 0.1mm
 ANGULAR ± 15'

FINISH
 DO NOT SCALE - REMOVE BURRS & SHARP EDGES

MATERIAL

ORIGINATOR
RMP
 REVISED

TITLE EXTRUDED CHANNEL			
SCALE	DRAWING NUMBER	PART NUMBER	
UNITS mm	SHEET 3 OF 4	APBC0842*	
STATUS	ISSUE	DATE	CHANGE
Released	3		
APPROVED			

LOCATION: C:\Users\Ron MacPhee\Desktop\Rubicon ID Projects\Airdri - 2016\ID1171 - Vision Detail Design\Up-dated CAD files\LS (New)\APBC0842.idw

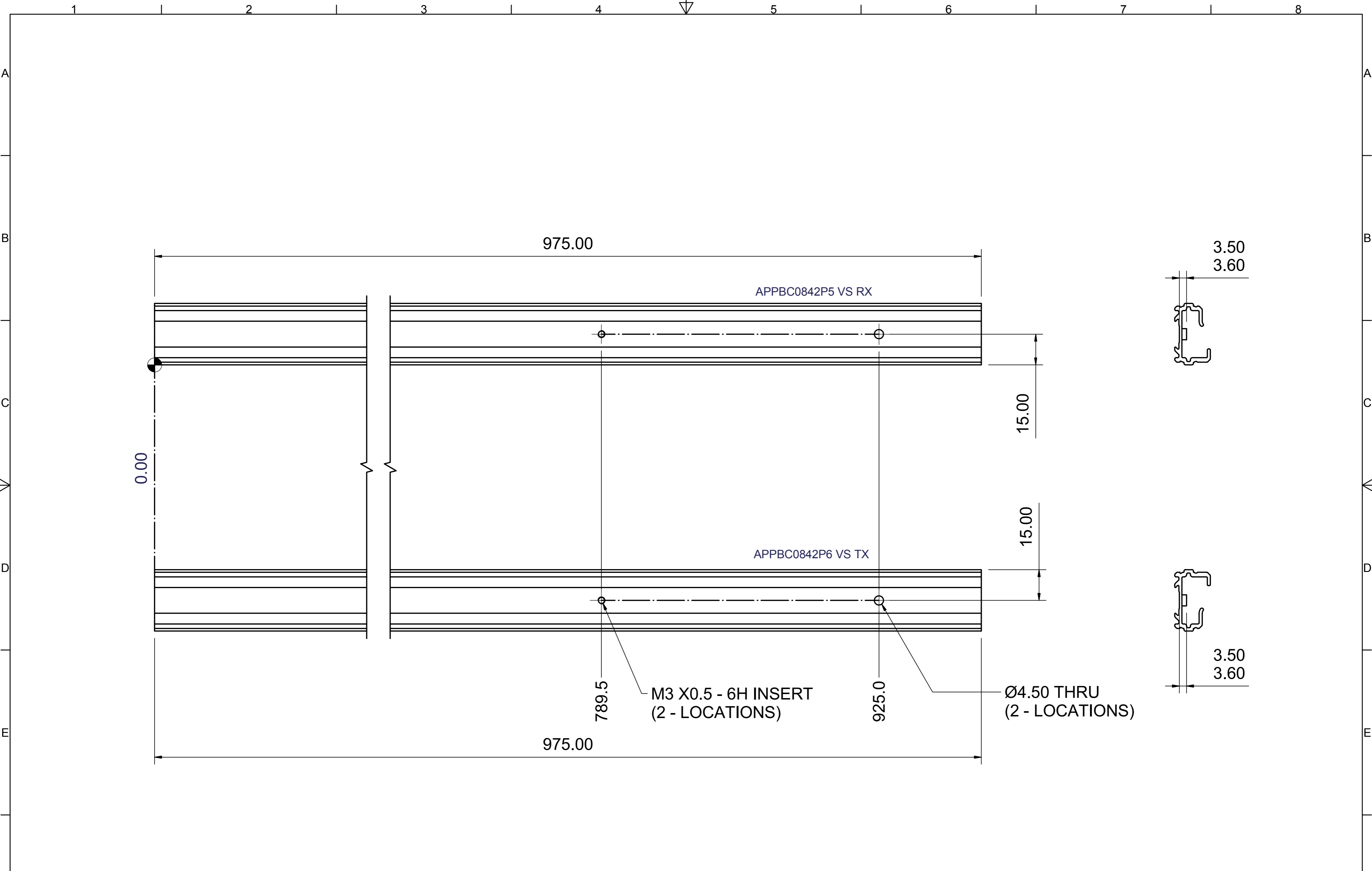

0.00

975.00

APPBC0842P5 VS RX

3.50
3.60

15.00

APPBC0842P6 VS TX

15.00

789.5

M3 X 0.5 - 6H INSERT
(2 - LOCATIONS)

925.0

Ø4.50 THRU
(2 - LOCATIONS)

3.50
3.60

975.00

AIRDRI LTD
Technology House, Oakfield Estate,
Eynsham, OXFORD OX29 4AQ
TEL +44(0)1865 882330
FAX +44(0)1865 881647
www.airdri.com
COPYRIGHT AIRDRI LTD 2002

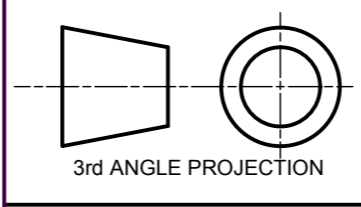

TOLERANCES
UNLESS STATED
LINEAR
X ± 0.5mm
X.X ± 0.3mm
X.XX ± 0.1mm
ANGULAR ± 15'

FINISH

MATERIAL

ORIGINATOR
RMP

TITLE
EXTRUDED CHANNEL

REVISED

SCALE

DRAWING NUMBER
APBC0842

PART NUMBER
APBC0842*

STATUS

ISSUE

DATE

CHANGE

APPROVED

Released

3

LOCATION: C:\Users\Ron MacPhee\Desktop\Rubicon ID Projects\Airdri - 2016\ID1171 - Vision Detail Design\Up-dated CAD files\LS (New)\APBC0842.idw