

SCALE 1:1

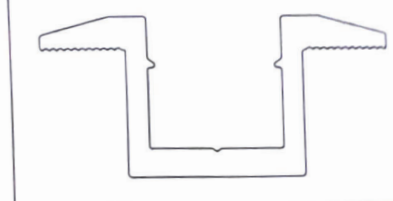

Q00743

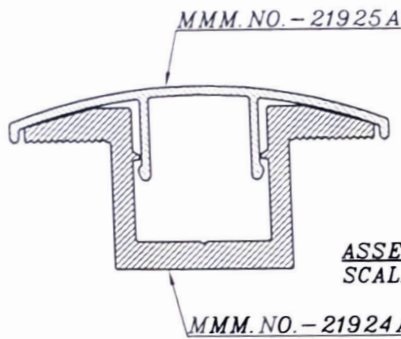
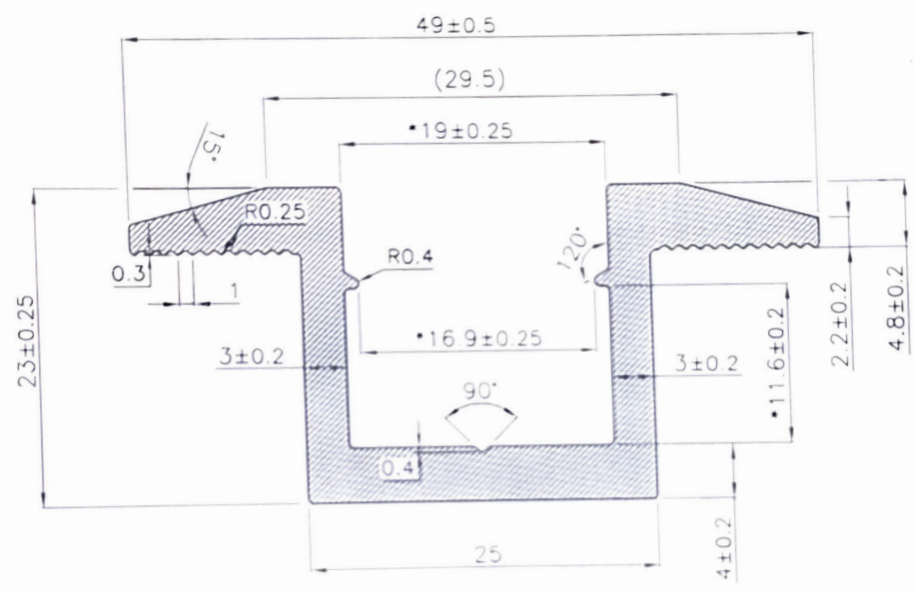

For ORNATE AGENCIES PVT. LTD.
 Authorised Signatory

NOTES:-

- 1. UNSPECIFIED CORNER RADIUS: 0.40 mm.
- 2. DIMENSIONS IN BRACKETS ARE NOT MEASURABLE & ARE FOR REFERENCE ONLY.

WITH DIN ISO 2768 - 1 class C = Coarse

Dimension Tolerance	0.5 - 3 ±0.2	3 - 6 ±0.3	6 - 30 ±0.5	30 - 120 ±0.8	120 - 400 ±1.2	400 - 1000 ±2.0
Character & Limits	0.5 - 3 ±0.4	3 - 6 ±1.0	6 - 30 ±2.0	30 - 120 ±3.0	120 - 400 ±4.0	400 - 1000 ±6.0
Degrees & Minutes	10 - 50 ±1'	10 - 50 ±1'	10 - 50 ±1'	10 - 50 ±1'	10 - 50 ±1'	10 - 50 ±1'

ALL DIMENSION ARE IN MM				UNSPECIFIED TOL ±0.2 mm	PERIMETER	183.010	AREA	301.933 mm ²
					CRITICAL DIM.	*	WEIGHT	0.815 Kg/M
					SEC. TYPE	SOLID	WT. RANGE	0.770-0.860 Kg/M
					ANGULARITY	±2°	ALLOY / TEMPER	6063 T6
					TWIST	1/4°/300mm/M	MMM. NO.	21924 A
					STRAIGHTNESS	1.7mm/M	SECTION No.	000-0000
					FLATNESS	WIDTHX0.005mm		
CHECKED	JITENDER	APPROVED		SCALE	2:1	CAVITY	-	1
DRAWN BY	Deewan	TYPE - XX - XXXX			DIE DIA	-	180 mm	-
CUSTOMER NAME -				MM METACRAFT.PVT.LTD.		PRESS	PRESS	PRESS
CUSTOMER REF NO -				Mid Clamp New		660	1100	1600



mm metacraft pvt. ltd.
 www.mmmetacraft.com