

Q01865

S. No.	Final Size, Extrusion B, mm	Wt. of Extruder Section Kg / Running meter
1	C 65 X 50	2.649
2	C 65 X 75	2.905
3	C 65 X 100	3.162
4	C 65 X 125	3.418
5	C 65 X 150	3.675
6	C 65 X 175	3.931
7		

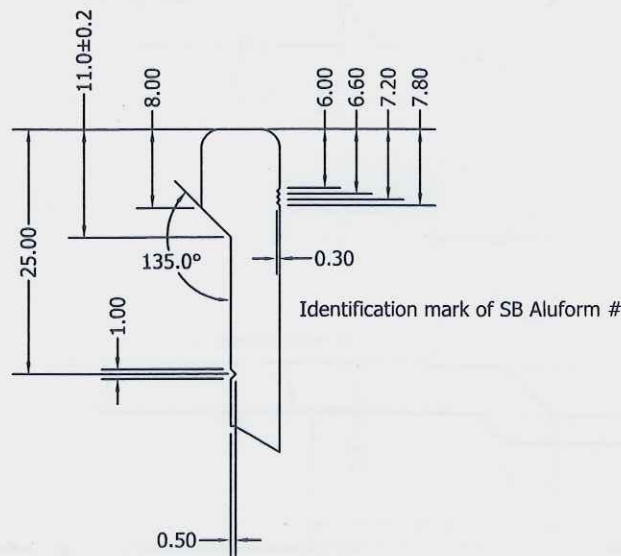

DETAIL A  
SCALE 2 : 1

NOTE -

- 1) All dimensions are in mm.
- 2) Material: Aluminum Alloy 6061 T6, unless otherwise specified.
- 3) All extrusion shall conform to BS-EN 755-9: 2001
- 4) Angular Tolerances  $\alpha = '0.75 \sim$  Degree
- 5) All extrusion, that will be supplied, shall be with Test Certificate & patrol inspection report.
- 6) **Not to Scale**

DRAWN	SSJ	29-03-2023	M/S SB FORMWORK SYSTEMS(I) PVT. LTD.		
CHECKED			TITLE		
QA			`C` Extruded Sections 65 x B x 1000 mm		
MFG			SIZE	DWG NO	REV
APPROVED			A3	`C` Section 65_50 to 175	R0
			SCALE	1 : 1	SHEET 1 OF 1