

BEFORE APPROVAL CHECK ALL DIMENSIONS PROPERLY



PROPOSED DRAWING

SCALE 1:1

Q00256

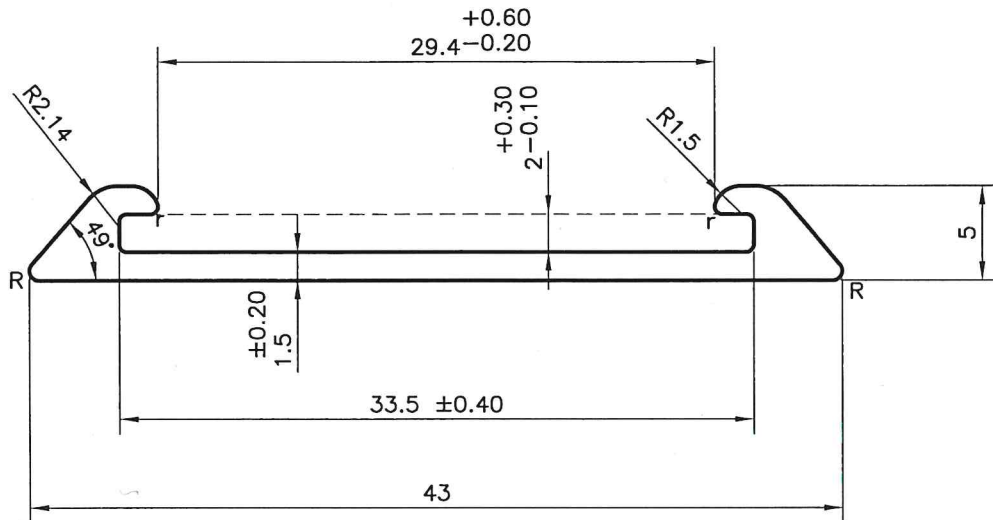

NOTE:-
 $r = 0.40R$
 $R = 0.50R$



JINDAL ALUMINIUM LTD.
 BHIWADI-301019 (INDIA)

	NAME	DATE
DRAWN	ASHUTOSH	08-12-2022
CHECKED	<i>Junil</i>	9-12-22
APPROVED	<i>Up</i>	9/12/22

1. ALL DIMENSIONS ARE IN mm.
2. ROUND OFF ALL SHARP CORNERS WITH 0.40 mm.
3. TOLERANCES WILL BE AS PER BS:EN-755-9 , UNLESS OTHERWISE SPECIFIED

SCALE	1:1&2.5:1
AREA mm ²	86.64
PERIMETER mm.	103.62
WEIGHT kg/m	0.234

PARTY'S NAME	M/s UPTech
PARTY'S DRAWING No.	AS PER DRAWING (Q00256)
ALLOY & TEMPER	6063-T6
DESCRIPTION	-

DRAWING No.	SECTION No.
-	