

BEFORE APPROVAL CHECK ALL DIMENSIONS PROPERLY

PROPOSED DRAWING

Q00267

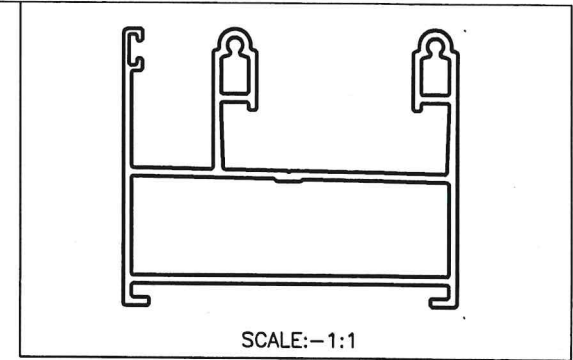

SCALE: -1:1

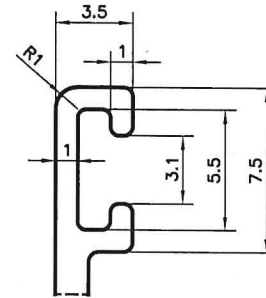
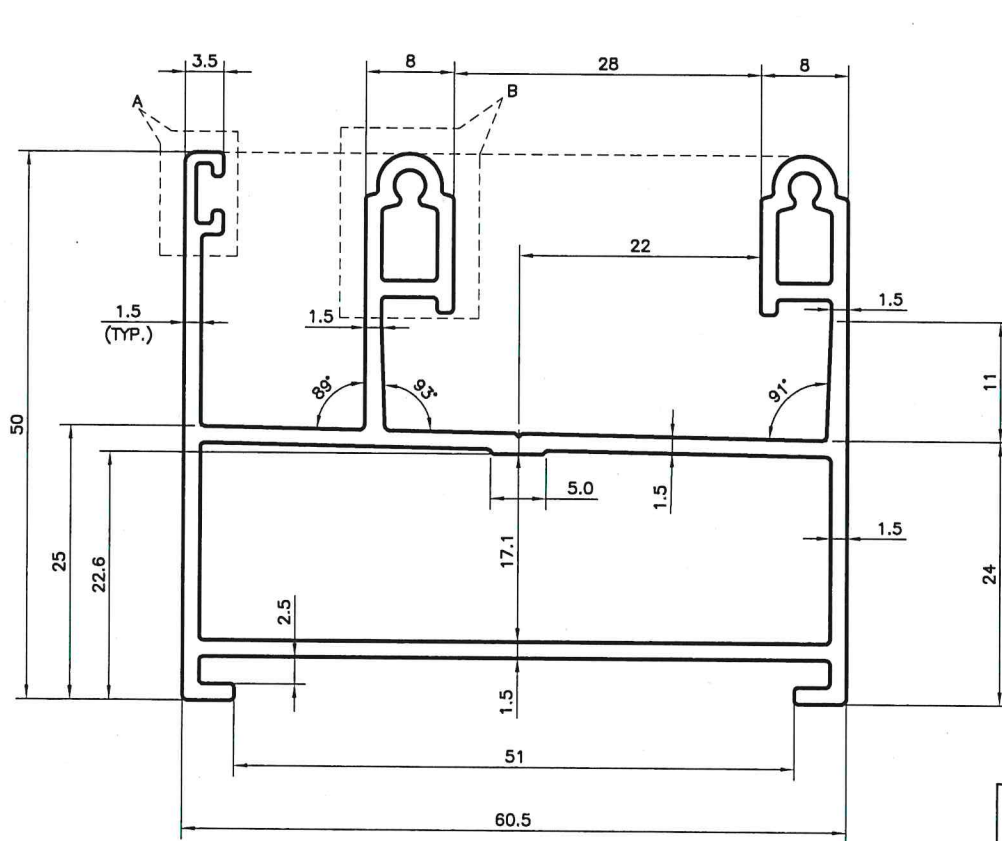

DETAIL A
SCALE 4:1

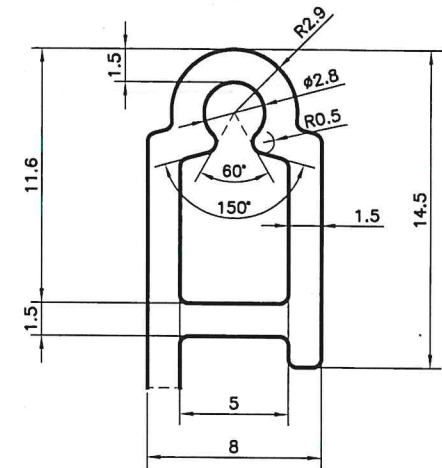

DETAIL B
SCALE 4:1

 SYMBOL OF QUALITY AN ISO 9001 COMPANY	JINDAL ALUMINIUM LTD. BHIWADI-301019 (INDIA)		NAME	DATE
	DRAWN	ASHUTOSH	20-12-2022	
	CHECKED			
	APPROVED			
1. ALL DIMENSIONS ARE IN mm. 2. ROUND OFF ALL SHARP CORNERS WITH 0.40 mm. 3. TOLERANCES WILL BE AS PER BS:EN-755-9 , UNLESS OTHERWISE SPECIFIED			SCALE	1:1&2:1
			AREA mm ²	448.33
			PERIMETER mm.	375.45
			WEIGHT kg/m	1.211
PARTY'S NAME	M/s. INDO ALUSYS IND. LTD.		DRAWING No.	SECTION No.
PARTY'S DRAWING No.	AS PER DRAWING (Q00267)			
ALLOY & TEMPER	6063-T6			
DESCRIPTION	-			