

ASSEMBLY SCALE 1:1

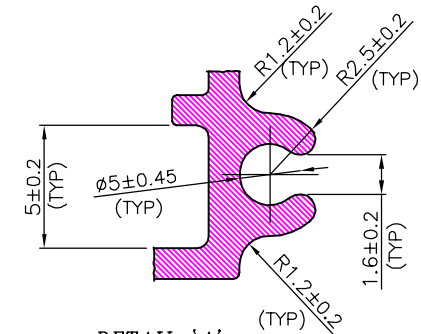

DETAIL-'A'
SCALE 4:1

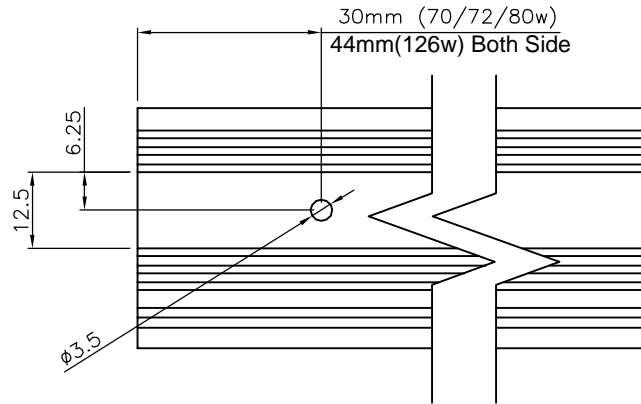
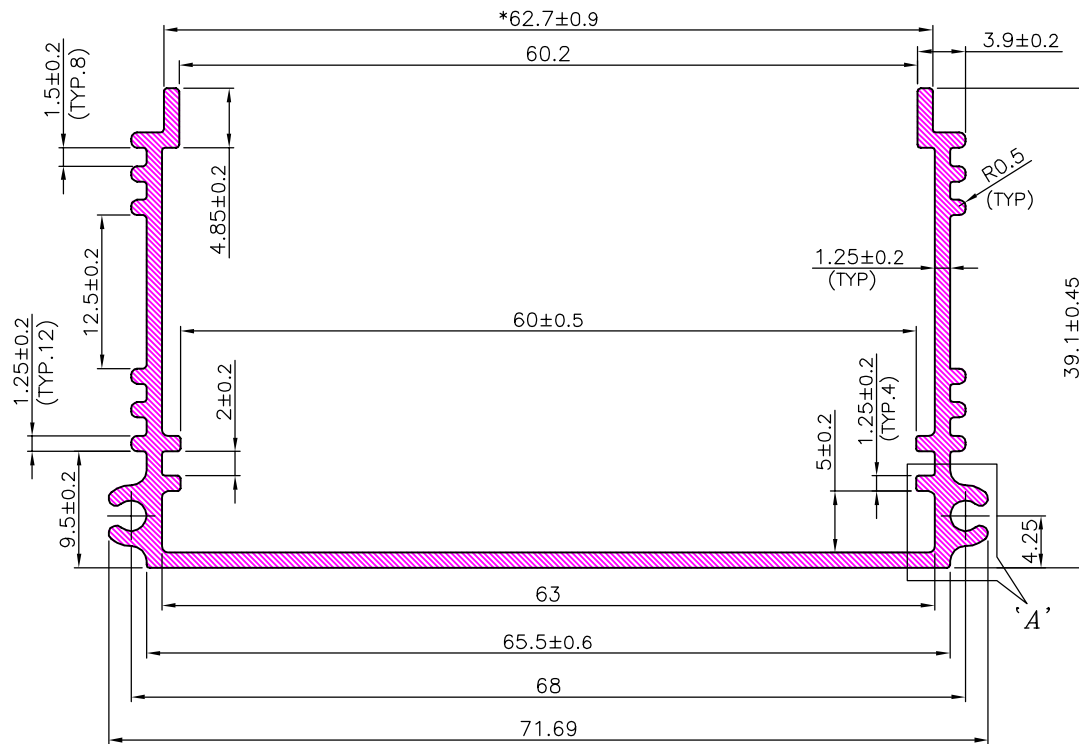

SCALE 2:1

Note:-

Length 128mm For 70 / 72 / 80W
Length 150mm For 126W

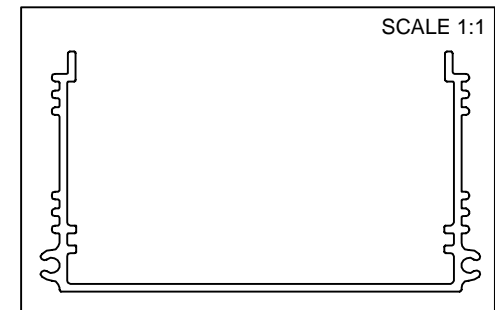

SCALE 1:1

	DRAWING NO:-	SLP-20-00190-19-V1		SURYA <small>(Surya Roshni Limited, Lumbari Business Unit)</small>	
	TITLE:-	Driver Extrusion Housing			
SIZE:-	A0	MATERIAL:-	Aluminum 6063 T6	1.	11-09-2019
WEIGHT:-		FINISH:-	Anodized	2.	
SCALE 1:1		Designed by :-	Anand Singh	Approved by :-	Dr.Amit Tyagi
Tolerance:- ± 0.1mm		Date:-	17-06-2019	Date:-	17-06-2019
NOTE: All Dimensions are in mm. Scale and tolerance are marked unless otherwise noted				3.	
				4.	
				5.	
				6.	

PROPRIETARY AND CONFIDENTIAL THE INFORMATION CONTAINED IN THIS DRAWING IS THE SOLE PROPERTY OF SURYA ROSHNI LTD.
COPYRIGHT 2012 ANY REPRODUCTION IN PART OR AS A WHOLE WITHOUT THE WRITTEN PERMISSION OF SURYA ROSHNI LTD IS PROHIBITED.