

BILL OF MATERIAL

ITEM	QTY	PART NAME	PART NUMBER	MATERIAL SPEC.	MASS (Kg)	CA (in ²)	TSA (in ²)
1	--	INNER	I-CE2022294-D11	Al 6061-T6 or Al 6082-T6	0.136kg	11.84in ²	23.183in ²

VERSION	PLACES	DESCRIPTION	CHANGED BY	DATE	APD. BY
A	---	INITIAL RELEASE	-----	22.12.2022	S.A.

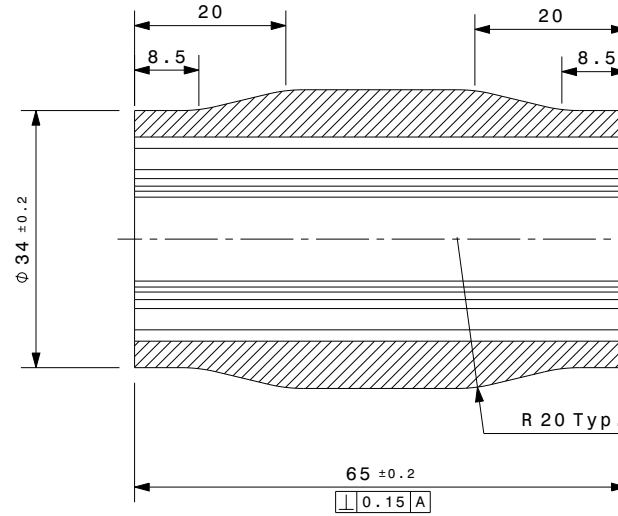
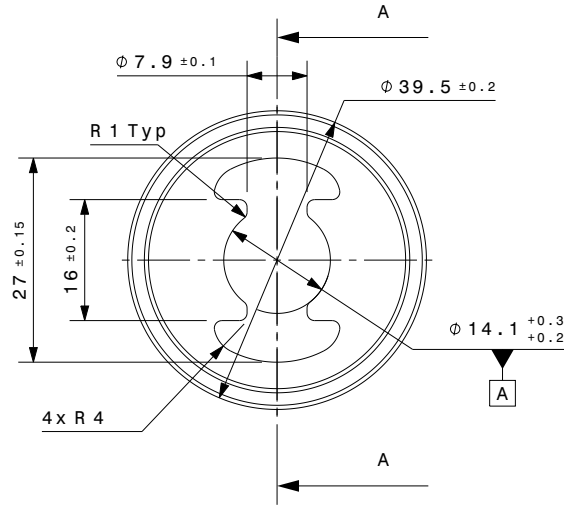

Section view A-A

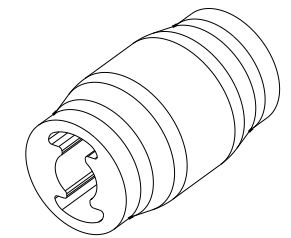

Isometric view

NOTES

- * INNER CRUSH LOAD Min. 115 kN.
- * FOR UNSPECIFIED DIMENSION REFER 3D CAD DATA.
- * REMOVE ALL SHARP EDGES AND BURRS.

<input checked="" type="checkbox"/> FOR QUOTATION	DRAWN BY	MANISH KUMAR		PART NAME	INNER	 ANAND NVH PRODUCTS (P) LTD N.H.-8 SECTOR 35 GURGAON HARYANA 122001 (INDIA) PROPERTY OF ANP					
<input checked="" type="checkbox"/> FOR COSTING	CHECKED BY	PANKAJ KASAR		PART NUMBER	I-CE2022294-D11						
<input type="checkbox"/> FOR DEVELOPMENT	APPROVED BY	S.ADHIMOOMAM		TOLERANCED: ISO 2768-mk ISO 8015 (ASC) : ANAND SPECIAL CHARACTERISTIC							
<input type="checkbox"/> FOR SERIAL PRODUCTION	CAD SYSTEM: CATIA V5	PROTECTION MARK: ISO 16016	DATE: 22.12.2022	MODEL IS MASTER FOR ALL NON-DIMENSIONED FEATURES	SHEET	AI	SCALE	NTS	UNIT	mm	A