

DESC. OF CHANGES

DATE

REV.

TOLERANCES

DIV. CLASS	A	B	C	D
0-5	±0.07	±0.1	±0.15	±0.2
5-20	±0.1	±0.15	±0.2	±0.3
20-50	±0.15	±0.2	±0.3	±0.4
50-100	±0.2	±0.3	±0.4	±0.6
100~	±0.3	±0.5	±0.6	±1.0
ANGLE	± 20'	± 40'	± 30'	± 3

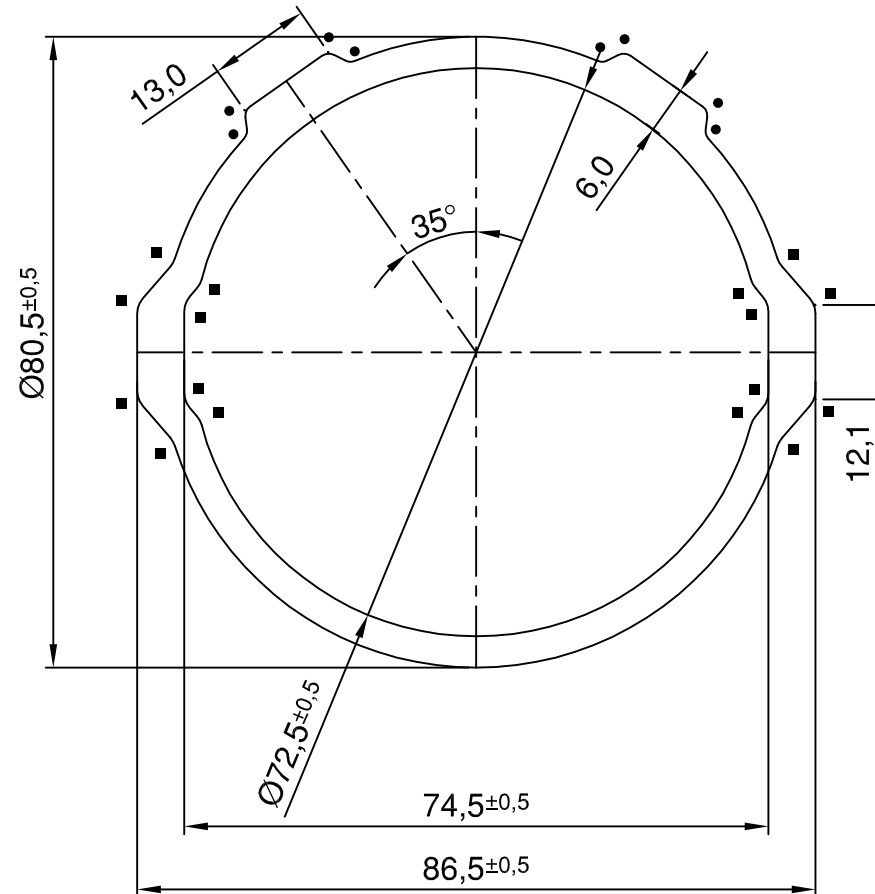

## Note

1. Material - Aluminium
2. ● = 1.5 MM RADIUS
3. ■ = 3.0 MM RADIUS
4. Unspecified Radius 0.4mm
5. Part should be ROHS compliant.
6. Part must be free from Damage, scratch, dust, etc.

MATERIAL	FINISH	F. MARK	QUANTITY	SCALE	TOLERANCE	PRODUCT
---	---	---	---	---	---	8100 Lumen 170 Lm/watt
						<u>DESCRIPTION</u>
						Pole Holder
						<u>COMP. NO.</u>
						---
ELIN ELECTRONICS LIMITED GHAZIABAD (U.P.)						

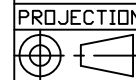

UNIT

M.M.

---

---

---

---

---

---

---