

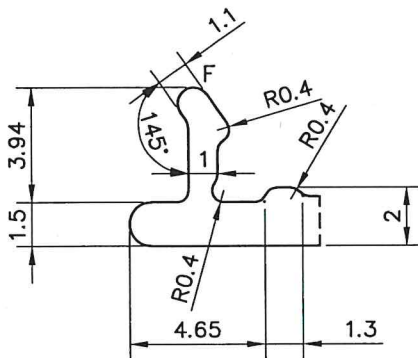

SCALE: -1:1

BEFORE APPROVAL CHECK ALL DIMENSIONS PROPERLY

PROPOSED DRAWING

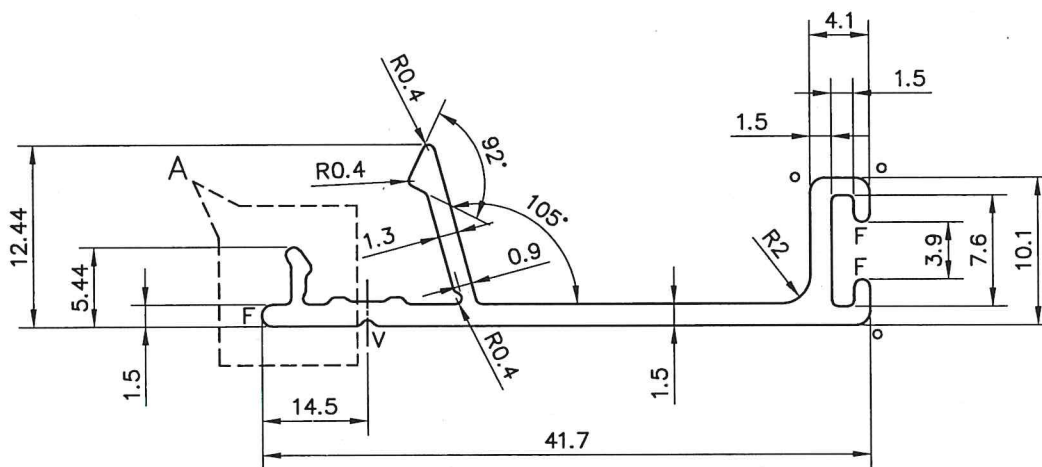

DETAIL A
SCALE 4:1

NOTE:-

F = FULL RADIUS

o = 1.00R

V = $0.45 \times 90^\circ$



SYMBOL OF QUALITY
AN ISO 9001 COMPANY

JINDAL ALUMINIUM LTD.

BHIWADI-301019 (INDIA)

1. ALL DIMENSIONS ARE IN mm.
2. ROUND OFF ALL SHARP CORNERS WITH 0.40 mm.
3. TOLERANCES WILL BE AS PER BS:EN-755-9 , UNLESS OTHERWISE SPECIFIED

	NAME	DATE
DRAWN	AMIT	30-12-2022
CHECKED		
APPROVED		
SCALE	1:1,2:1&4:1	
AREA mm ²	103.01	
PERIMETER mm.	143.34	
WEIGHT kg/m	0.278	
DRAWING No.	SECTION No.	
-	-	
-	-	
-	-	

PARTY'S NAME	M/s. INTEGRITY WINDOWS & DOORS PVT. LTD.
PARTY'S DRAWING No.	AS PER DRAWING (137.952)
ALLOY & TEMPER	6063-T6
DESCRIPTION	---