

BEFORE APPROVAL CHECK ALL DIMENSIONS PROPERLY

PROPOSED DRAWING

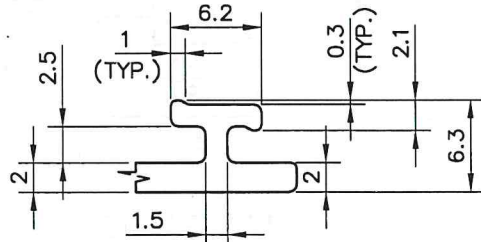

DETAIL A
SCALE 2:1

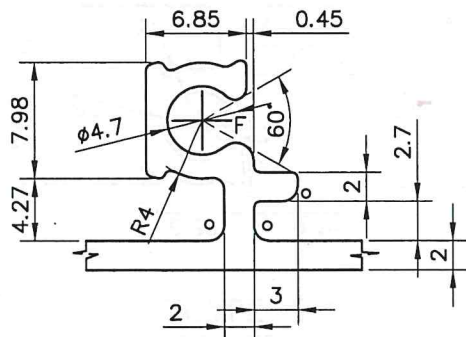

DETAIL B
SCALE 2:1

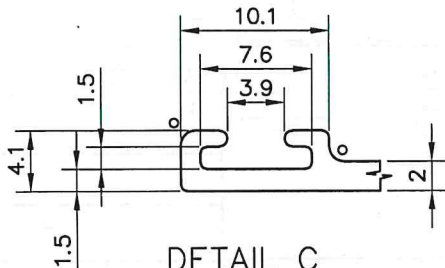

DETAIL C
SCALE 2:1

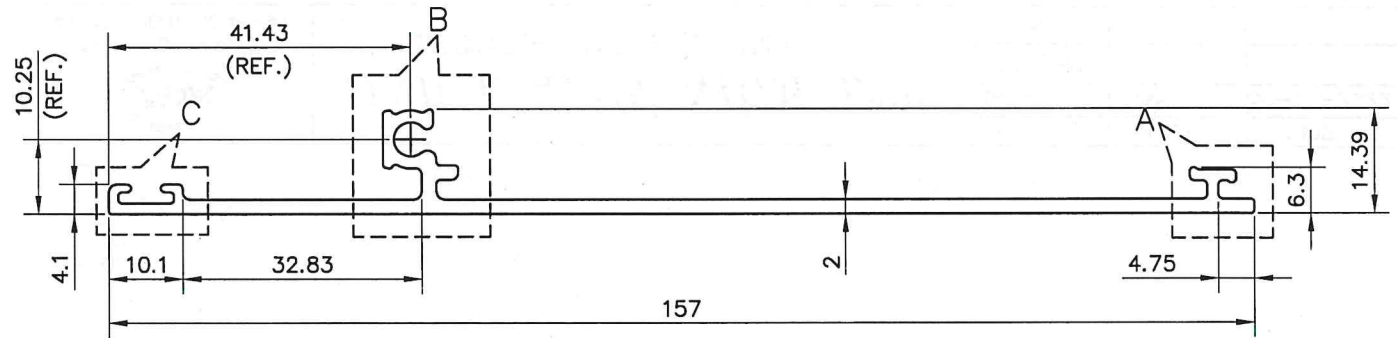

NOTE:-

F = FULL RADIUS

o = 1.00R

 SYMBOL OF QUALITY AN ISO 9001 COMPANY	JINDAL ALUMINIUM LTD. BHIWADI-301019 (INDIA)		NAME	DATE
	DRAWN	AMIT	30-12-2022	
	CHECKED			
			APPROVED	
1. ALL DIMENSIONS ARE IN mm. 2. ROUND OFF ALL SHARP CORNERS WITH 0.40 mm. 3. TOLERANCES WILL BE AS PER BS:EN-755-9 , UNLESS OTHERWISE SPECIFIED			SCALE	1:1 & 2:1
			AREA mm ²	381.45
			PERIMETER mm.	397.48
PARTY'S NAME	M/S. INTEGRITY WINDOWS & DOORS PVT. LTD.	WEIGHT kg/m	1.030	
PARTY'S DRAWING No.	AS PER DRAWING (137.951)	DRAWING No.	SECTION No.	
ALLOY & TEMPER	6063-T6			
DESCRIPTION	--			