

BEFORE APPROVAL CHECK ALL DIMENSIONS PROPERLY

PROPOSED DRAWING

PFO042

14

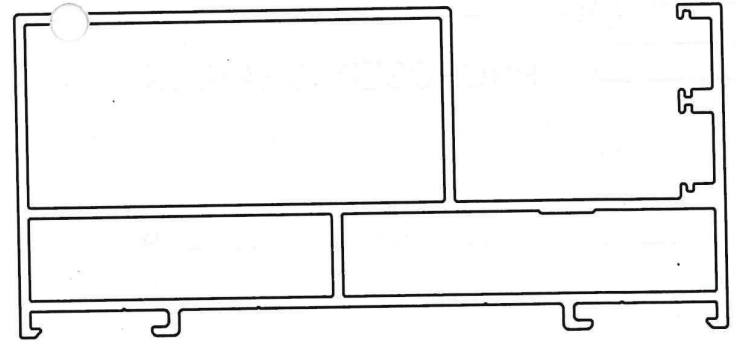
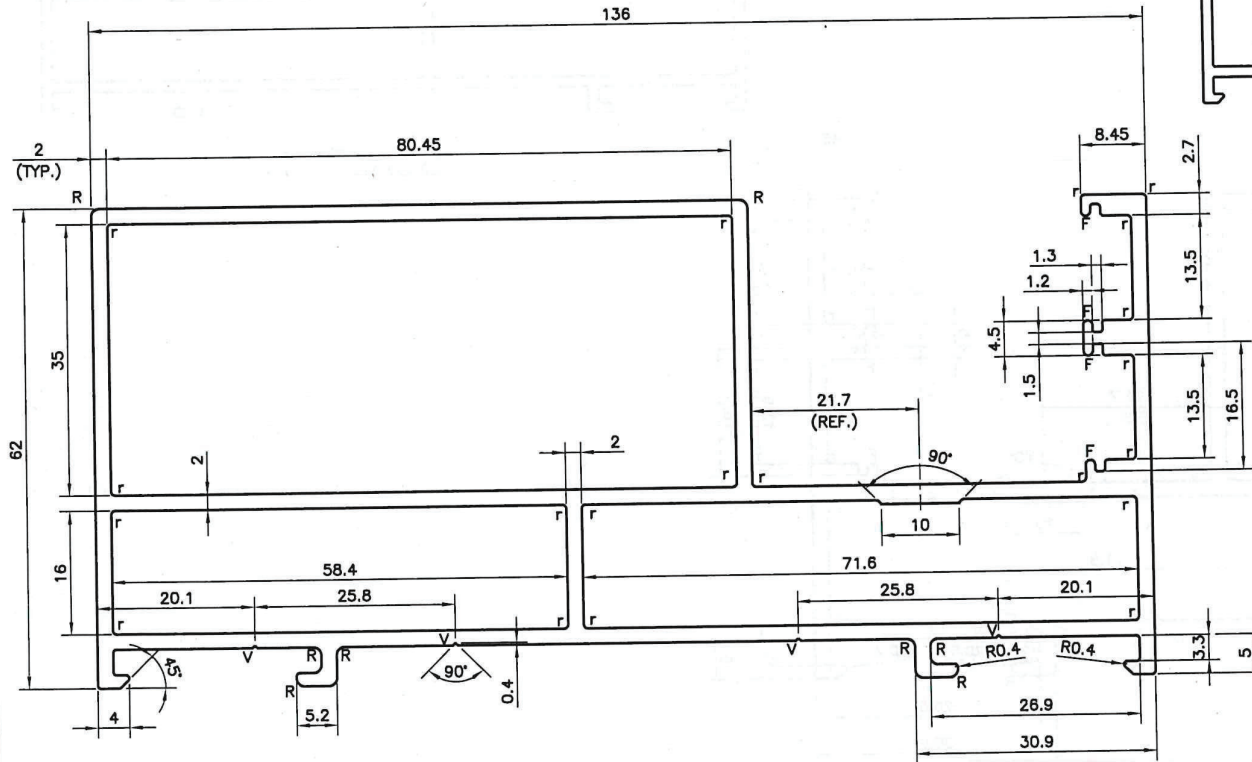

SCALE 1:1

NOTE:-

- F= FULL RADIUS
- r= 0.50 RADIUS
- R= 1.00 RADIUS
- V= 0.4x90° (V-GROOVE)

 SYMBOL OF QUALITY AN ISO 9001 COMPANY	<b>JINDAL ALUMINIUM LTD.</b> BHIWADI-301019 (INDIA)		NAME	DATE
	DRAWN	ASHUTOSH	31-12-2022	
	CHECKED			
	APPROVED			
1. ALL DIMENSIONS ARE IN mm. 2. ROUND OFF ALL SHARP CORNERS WITH 0.40 mm. 3. TOLERANCES WILL BE AS PER BS:EN-755-9, UNLESS OTHERWISE SPECIFIED			SCALE	1.5:1
			AREA mm <sup>2</sup>	1141.68
			PERIMETER mm.	546.46
			WEIGHT kg/m	3.083
PARTY'S NAME	M/s. PRANAV DOORS & WINDOWS PVT. LTD.		DRAWING No.	SECTION No.
PARTY'S DRAWING No.	AS PER DRAWING (2 TRACK SIDE NIGHT VENT)			
ALLOY & TEMPER	6063-T6			
DESCRIPTION	-			