

BEFORE APPROVAL CHECK ALL DIMENSIONS PROPERLY

PROPOSED DRAWING

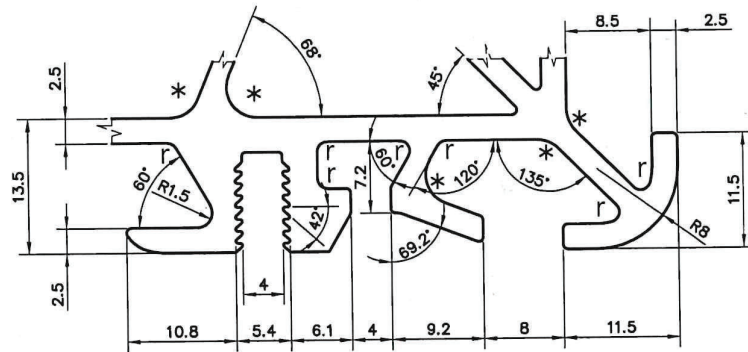

29

PF0009

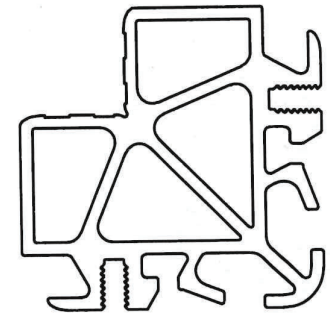

DETAIL A
SCALE 2:1

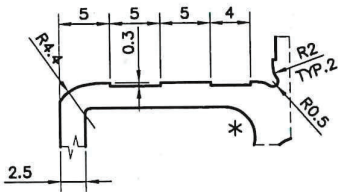

DETAIL B
SCALE 2:1

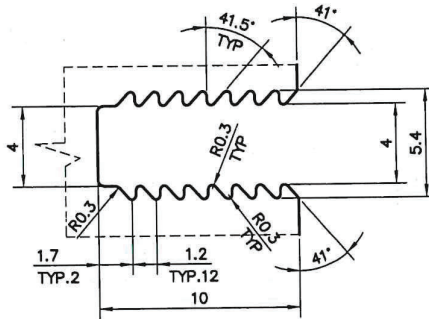

DETAIL C
SCALE 4:1

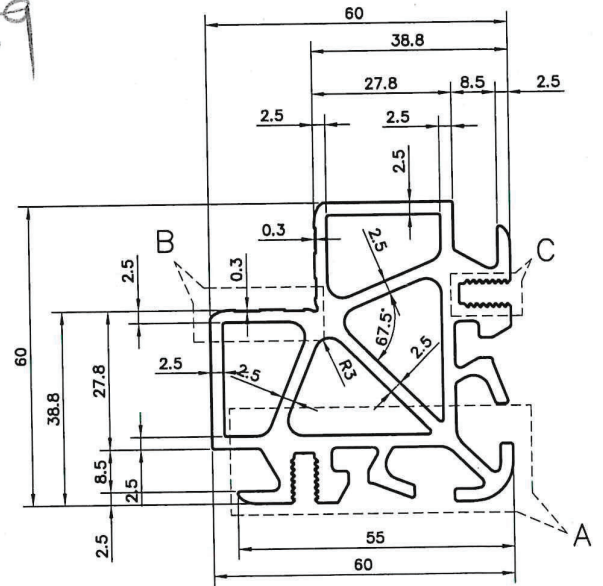

NOTE:-
r = 1.00 R
* = 3.00 R

<p>JINDAL SYMBOL OF QUALITY AN ISO 9001 COMPANY</p>	<p>JINDAL ALUMINIUM LTD. BHIWADI-301019 (INDIA)</p>		NAME	DATE
	DRAWN	AMIT	22-12-2022	
	CHECKED			
<p>1. ALL DIMENSIONS ARE IN mm. 2. ROUND OFF ALL SHARP CORNERS WITH 0.40 mm. 3. TOLERANCES WILL BE AS PER BS:EN-755-9, UNLESS OTHERWISE SPECIFIED</p>			APPROVED	
<p>PARTY'S NAME M/s. PRANAV DOORS AND WINDOWS PVT. LTD.</p>			SCALE	1:1,2:1,4:1
			AREA mm ²	1074.45
<p>PARTY'S DRAWING No. AS PER DRAWING(CORNER CONNECTOR PROFILE)</p>			PERIMETER mm.	2327.24
			WEIGHT kg/m	2.901
<p>ALLOY & TEMPER 6063-T6</p>			DRAWING No.	SECTION No.
<p>DESCRIPTION -</p>				