

X	XX	DRAW / TOOL / 1
✓		REVISION- 02 / 10.3 .99

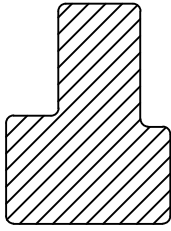

ACTUAL SIZE

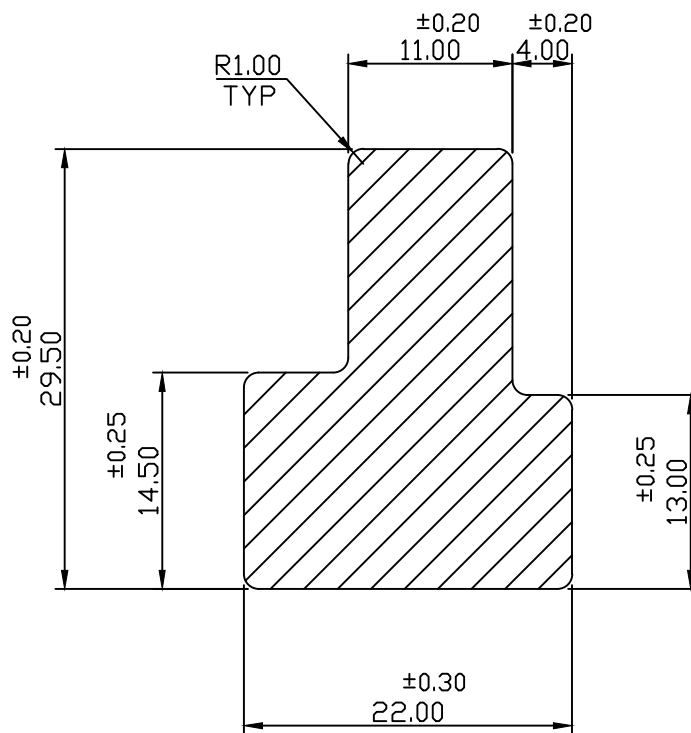

DETAILED SECTION DRAWING
(SCALE - 2 : 1)

REVISION-1

> DIMENSION CHANGE FROM 16.00 TO 14.50

TOLERANCE AS PER CUSTOMER DRAWING

UNSPECIFIED CORNER RADIUS = 1.0 MM

CEL CENTURY EXTRUSIONS LTD. KHARAGPUR, W.B.

CUST. M/S - SWASTIKA AUTOMATICS, FARIDABAD					DFR. NO.	10
CUST DRG. / SAMPLE	TC-EX-187		AREA	477.142 MM ²		
	SEC TYPE	S	WEIGHT	1.288 KG/M	DRN/DATE	ANANDA 06.05.2016
	CONT. SIZE	7"	WT. RANGE	-	CHKD/DATE	R.S.Gupta
	NO. OF CAV.	01	PERIMETER	EXT- 99.57 MM	APPD/DATE	R.S.Gupta
01/11.05.2016	EXT- RATIO	56		INT.- - MM	SCALE	1 : 1 & 2 : 1
REV NO. / DATE	SIGNATURE	DIE FACTOR	77	C . C . D		
	ALLOY	6061	CEL DRG.NO.	I-9868R1	CEL SEC.NO.	18066
	ALL DIMENSIONS ARE IN MM.					