

REVISION STATUS		
REV. NO.	DATE	REVISIONARY
00	01.07.2022	> New Counter Drawing Drawn
01	01.05.2022	> Tolerance changed 9.50(+0.10/-0.30) to 9.50(+0.10/-0.20)
		16.00±0.30 to 16.00±0.20 , 44.20±0.30 to 44.20±0.20
		> Dimension changed 20.00 to 20.60

EXCLUSIVE SECTION

X	XX	DRAW / TOOL / 1
	✓	REVISION- 02 / 10.03.99
END USE : AUTOMOTIVE		

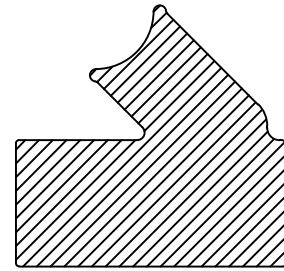

(SCALE - 1 : 1)

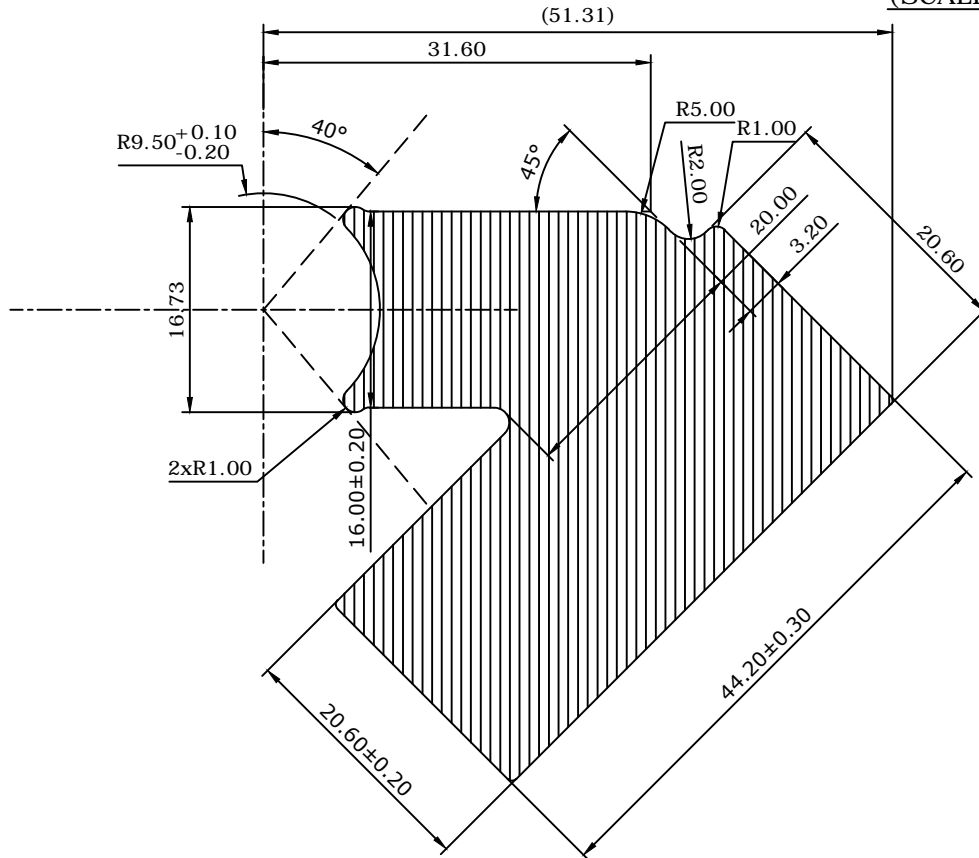

DETAILED SECTION DRAWING  
(SCALE - 2 : 1)

TOLERANCE AS PER BEST POSSIBLE

Unspecified Corner Radius = 0.50 mm.

**CEL CENTURY EXTRUSIONS LTD. KHARAGPUR, W.B.**

CUST.	M/s - SWASTIKA AUTOMATICS , FARIDABAD .			DFR NO.	NZ-091/22-23		
CUST DRG. / SAMPLE	CAA-01		AREA	1247.07 MM <sup>2</sup>	DRN/DATE	SOLEMAN 01.07.2022	
	SEC TYPE	S	WEIGHT	3.367 KG/M	CHKD/DATE	A. K. JENA	
	CONT. SIZE	7"	WT. RANGE	-	APPD/DATE	A. K. JENA	
	NO. OF CAV.	01	PERIMETER	EXT- 168.53 MM	SCALE	1 : 1 , 2 : 1	
01/05.07.2022	EXT- RATIO	22		INT- MM			
REV NO. / DATE	SIGNATURE	DIE-FACTOR	50	C . C . D	53.82 MM	CEL SEC.NO.	18926
		ALLOY-TEMPER	6005 T5	CEL DRG.NO.	I-32943R1	A4	
		ALL DIMENSIONS ARE IN MM.					