

REVISION STATUS		
REV. NO.	DATE	REVISIONARY
00	01.07.2022	> New Counter Drawing Drawn
01	05.07.2022	> Tolerance changed 17.50(+0.40/-0.00) to 17.50(+0.30/-0.00) & 26.40±0.30 to 26.40±0.20
		> Dimension changed 14.00 to 14.60
02	19.10.2022	> 14.60±0.20 Changed to 15.00±0.20
		> (59.33) Changed to (59.61)

EXCLUSIVE SECTION

X	XX	DRAW / TOOL / 1
	✓	REVISION- 02 / 10.03.99
END USE : AUTOMOTIVE		

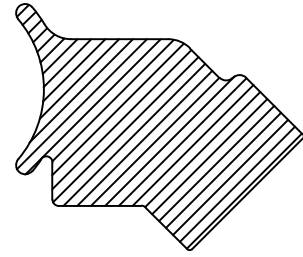

(SCALE - 1 : 1)

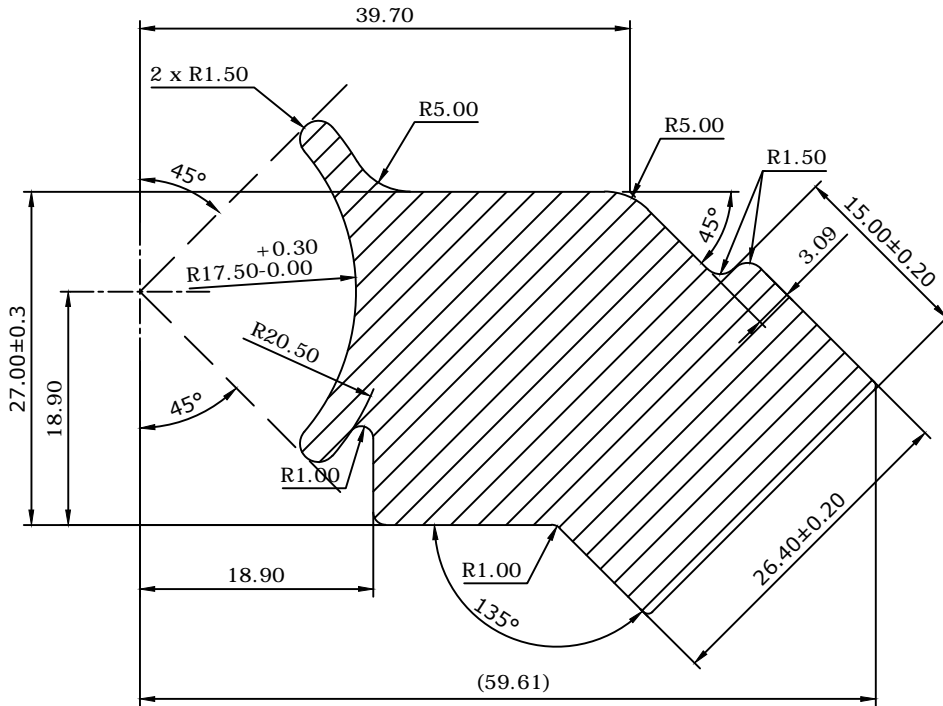

DETAILED SECTION DRAWING
(SCALE - 2 : 1)

TOLERANCE AS PER BEST POSSIBLE

Unspecified Corner Radius = 0.50 mm.

CEL CENTURY EXTRUSIONS LTD. KHARAGPUR, W.B.

CUST.	M/s - SWASTIKA AUTOMATICS, FARIDABAD.				DFR NO.	NZ-093/22-23	
CUST DRG. / SAMPLE	HC839GSCBA-02		AREA	1018.760 MM ²	DRN/DATE	SOLEMAN 01.07.2022	
	SEC TYPE	S	WEIGHT	2.751 KG/M	CHKD/DATE	A. K. JENA	
	CONT. SIZE	7"	WT. RANGE	-	APPD/DATE	A. K. JENA	
02/19.10.2022	NO. OF CAV.	01	PERIMETER	EXT- 149.50 MM	SCALE	1 : 1	
01/05.07.2022	EXT- RATIO	27		INT- MM			
REV NO. / DATE	SIGNATURE	DIE-FACTOR	55	C. C. D	52	MM	
		ALLOY-TEMPER	6005 T5	CEL DRG.NO.	I-32944R2	CEL SEC.NO.	18927
		ALL DIMENSIONS ARE IN MM.					A4