

**CUSTOMER APPROVAL**

<b>COMPANY RUBBER STAMP</b>	DATE:
	SIGN:

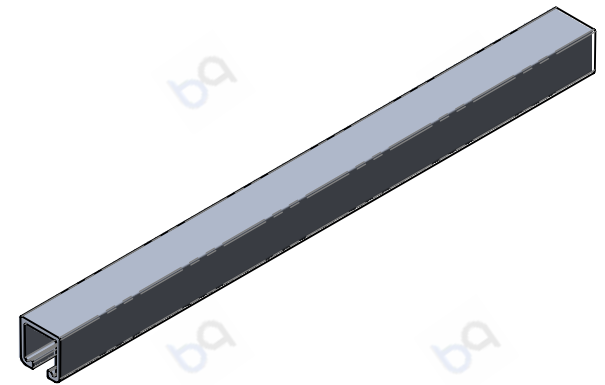
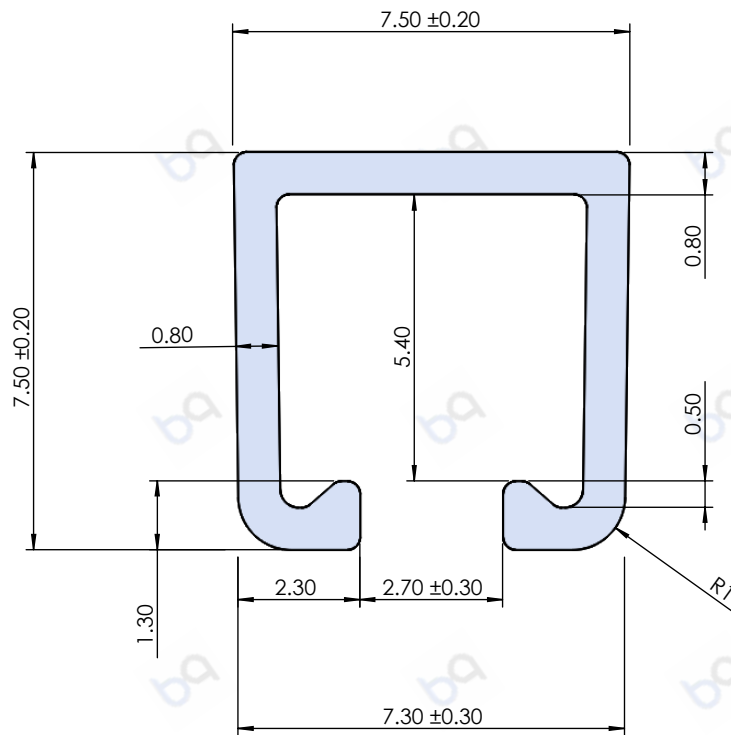

**CUSTOMER FILL THIS:-**

Only dimension check purpose , Feasibility has not been done .

Please mark the critical dimensions as circle . And please provide the fitting attachment of this dies ( at least 4 set )

Please let me know the following detail for new development as given below

1 - Alloy :-

2 - Hardness :-

3 - Cut length :-

4 - Material Finish :-

5 - Packing standard :-

6 - Part application :-

**NOTES:-**

- UNSPECIFIED CORNER RADIUS = 0.25 mm
- UNSPECIFIED TOLERANCES = ± 0.20 mm
- ALL OTHER GENERAL TOLERANCE WILL BE AS PER IS 3965 (1981) AND IS 6477 (1983) FOR SOLID AND HOLLOW PROFILE RESPECTIVELY.
- ALL DIMENSIONS ARE IN MM.

TOTAL PERIMETER:- mm	
EXTERNAL PERIMETER:- mm	
REVISION NO:- 00	REVISION DATE:-
REVISION CHANGE:-	
PART NO. :-	
PART NAME:-	CUT LENGTH:-
DRAWN BY :- RAKESH	CHECKED BY:- SHIVAM APPROVED BY:- SUJEET



**Balaji Aluminium Extrusions Pvt. Ltd.**  
Plot No :- 109, SECTOR-16, HSIIDC, Bahadurgarh, Haryana-124507

MATERIAL :- 6063-T6	AREA:- 19.43 Sq. mm
DATE :- 16-04-2022	WT/3660 mm:- 0.19032 Kg
FINISH:-	BALAJI MODEL NO. :- M-2028
CUSTOMER:- Aflux	BALAJI DRAWING NO. :-