

BEFORE APPROVAL CHECK ALL DIMENSIONS PROPERLY

PROPOSED DRAWING

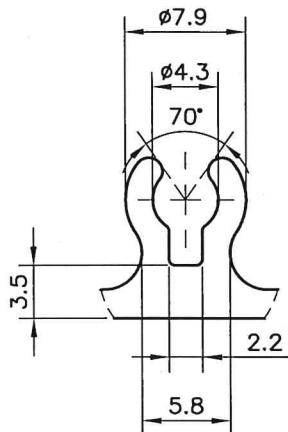

DETAIL A  
SCALE 2:1

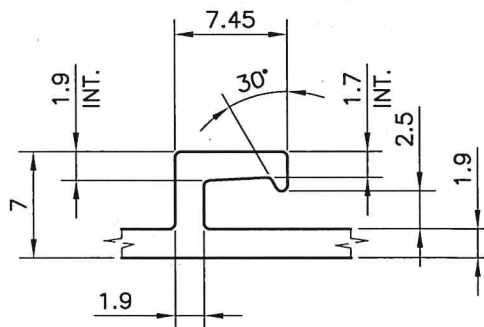

DETAIL B  
SCALE 2:1

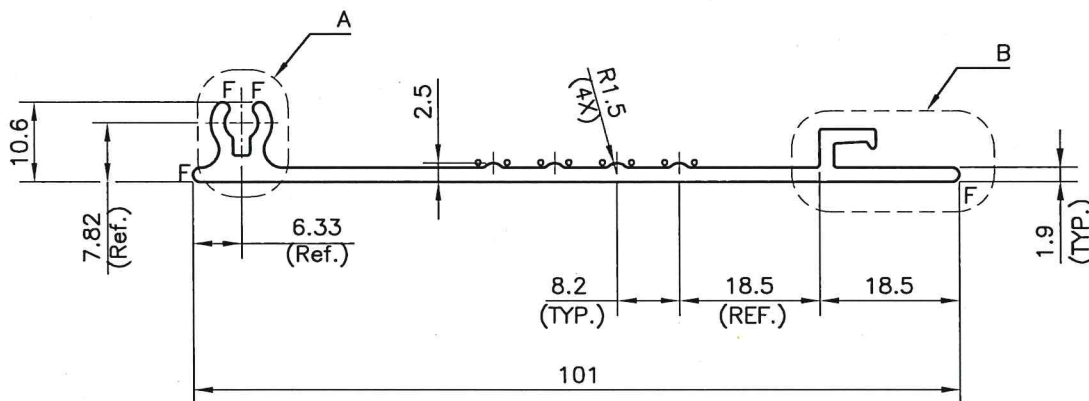

NOTE:-

F= FULL RADIUS

$\phi = 1.00R$



SYMBOL OF QUALITY  
AN ISO 9001 COMPANY

**JINDAL ALUMINIUM LTD.**  
BHIWADI-301019 (INDIA)

1. ALL DIMENSIONS ARE IN mm.
2. ROUND OFF ALL SHARP CORNERS WITH 0.40 mm.
3. TOLERANCES WILL BE AS PER BS:EN-755-9 , UNLESS OTHERWISE SPECIFIED

PARTY'S NAME M/s. UNITED CONCEPTS & SOLUTIONS PVT. LTD.

PARTY'S DRAWING No. AS PER SAMPLE

ALLOY & TEMPER 6063-T6

DESCRIPTION

		NAME	DATE
DRAWN		AMIT	23-01-2023
CHECKED			
APPROVED			
SCALE		1:1&2:1	
AREA mm <sup>2</sup>		254.12	
PERIMETER mm.		255.99	
WEIGHT kg/m		0.686	
DRAWING No.		SECTION No.	
-		-	
-		-	
-		-	