

LTRS		REVISIONS		
CN NUMBER	DATE	ORIGINATOR	REVIEWER	CN APPROVER
FIRST RELEASED HC844G5CBA-01				
NPL2000288	20200217	GKO	HSIN1	BCHO1

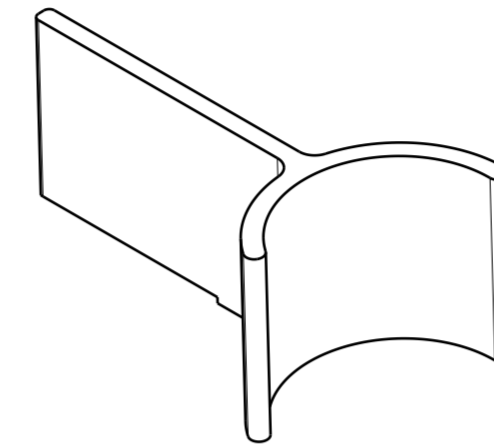

ISOMETRICE VIEW

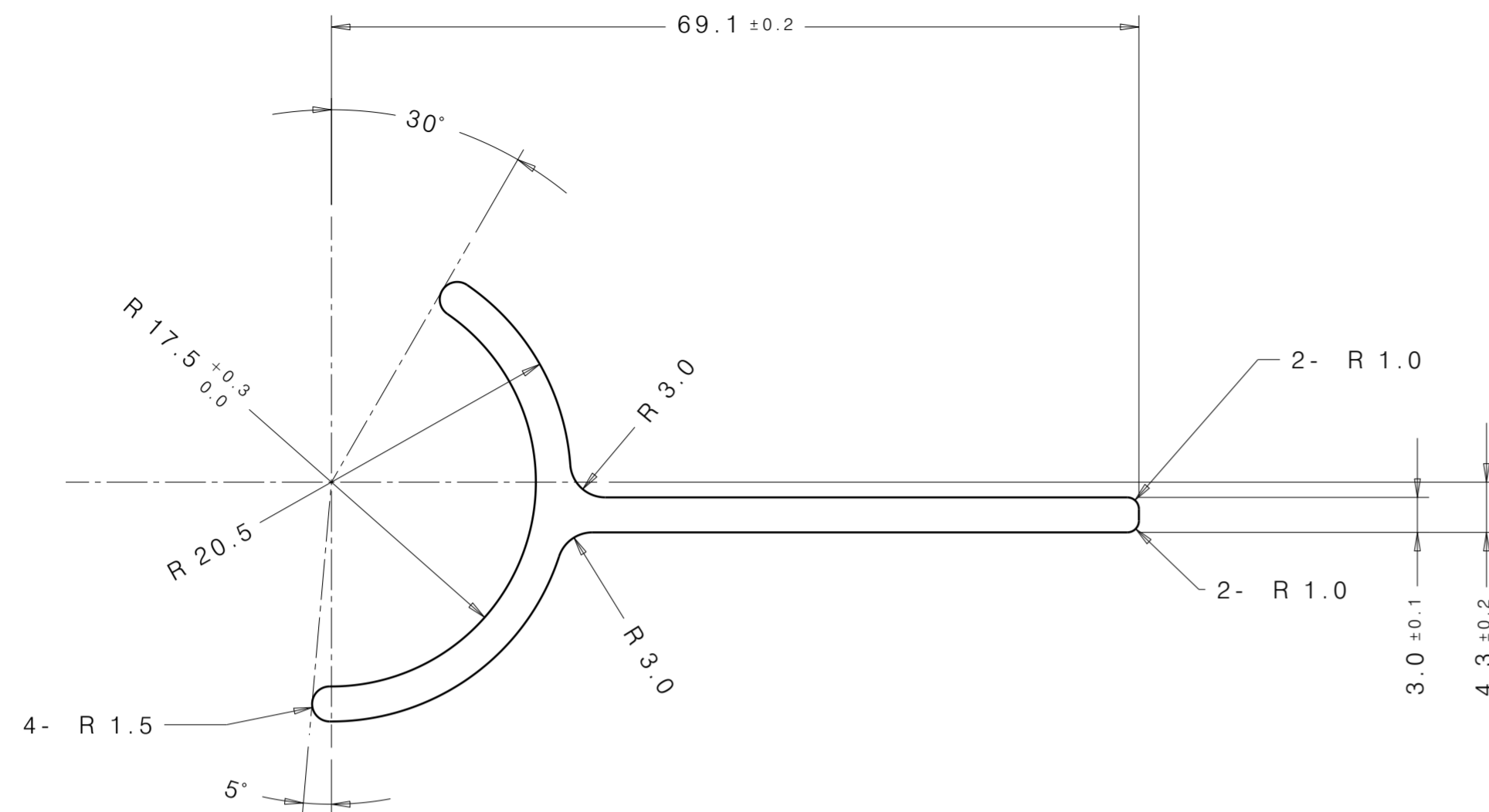
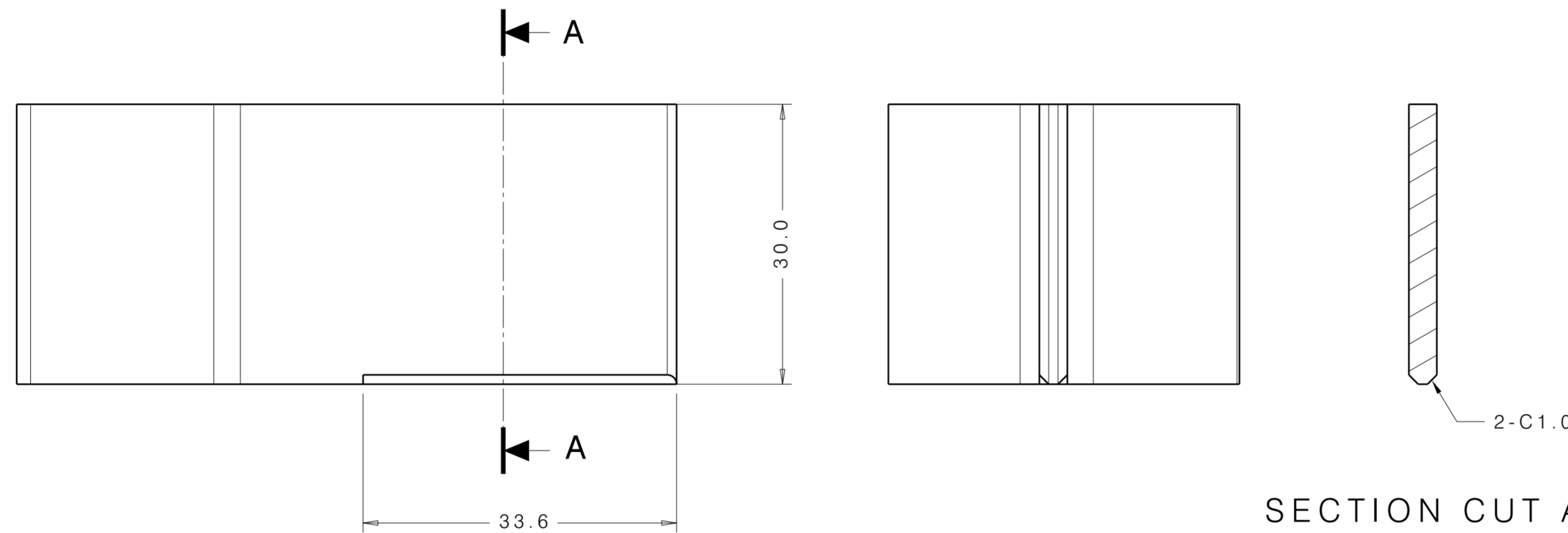

SECTION CUT A-A
SCALE: 2:1

주 기

- 단면에 유해한 BURR등이 없을 것.
- 지시하지 않은 모서리부는 R0.5
- 표면에 유지등 오염물질이 없을 것.
- MS201-02를 만족 할 것.
- 지시하지 않은 곳의 공차 : LINEAR ±0.5, ANGULAR ±1.0°
- 재질 : A6005-T5

NOTE

- BURRS, CRACKS AND FOREIGN MATERIALS ARE NOT ACCEPTABLE IF THEY ARE DETRIMENTAL TO ASSEMBLY FUNCTION AND SAFETY HANDLING.
- ALL UNSPECIFIED INSIDE BENDING RADIUS TO BE R0.5
- THERE IS NO OIL & FOREIGN MATERIAL ON THE SURFACE.
- MUST MEET MS201-02.
- GENERAL TOLERANCE : LINEAR ±0.5, ANGULAR ±1.0°
- MATERIAL : A6005-T5

DRAWING INFORMATION	1. THIS DRAWING AND ANY INTELLECTUAL PROPERTY RIGHTS THEREIN ARE PROPERTY OF HANON AND NO LICENSES ARE GRANTED UNDER THOSE RIGHTS.	4. MASS PRODUCTION MAKER SHOULD BE THE SAME TO PROTOTYPE MAKER. MASS PRODUCTION MAKER CAN BE CHANGED UNDER THE APPROVAL OF R&D CENTER AND QUALITY ASSURANCE TEAM.	6. DRAFTED IN ACCORDANCE WITH HANON ENGINEERING CAD STANDARD LAST REVISION.
	2. THIS DRAWING OR TECHNICAL INFORMATION IS IMMEDIATELY RETURNED AFTER USING WHEN HANON REQUESTS.	5. A SUPPLIER SHOULD NOT BE CHANGING ANY DESIGN WITHOUT AN UPDATED, APPROVED DRAWING FROM HANON. ANY CHANGES THAT THEY WANT TO IMPLEMENT SHOULD BE DISCUSSED AND AGREED TO BEFORE ANY PARTS ARE PRODUCED.	7. MUST COMPLY WITH GADSL, HANON SYSTEMS AND APPLICABLE OEM RESTRICTED SUBSTANCE MANAGEMENT STANDARDS.
	3. THE ITEM PRODUCED IN ACCORDANCE WITH THIS DRAWING SHOULD NOT BE USED OR SUPPLIED WITHOUT HANON'S APPROVAL.		8. THE TOOLING SUPPLIER SHOULD SUBMIT THE BELOW DOCUMENTS TO HANON PD ENGINEERS WITHIN 5 DAYS AFTER RECEIVING DRAWING. 1) TOOLING(DRAWING) REVIEW REPORT 2) TOOLING DEVELOPMENT PLAN 3) DESIGN CHANGE PROPOSAL (IF REQUIRED)

ORIGINATOR	DATE	CUSTOMER PART NUMBER	CUSTOMER-VEHICLE NAME
GKO	20200123		FORD-U725, P703
REVIEWER	DATE	OLD PART NUMBER	
HSIN1	20200130		
CN APPROVER	DATE	DESCRIPTION	
BCHO1	20200217		
3rd ANGLE PROJ	CAD TYPE	PART NAME	
SCALE 1:1	CATIA V5 R29	BRKT-(C)COND MTG	
SHEET 1/1	UNITS mm	PHASE	VERSION
DWG SIZE A2		PL	00